

Belt Conveyors

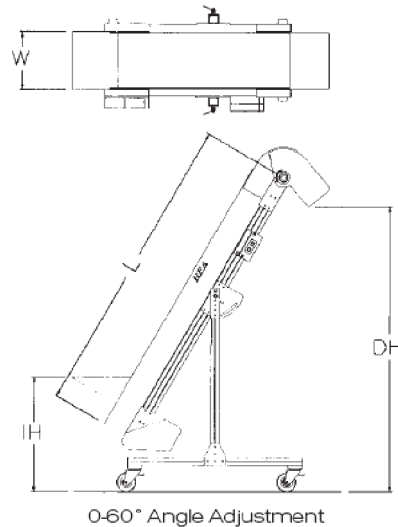
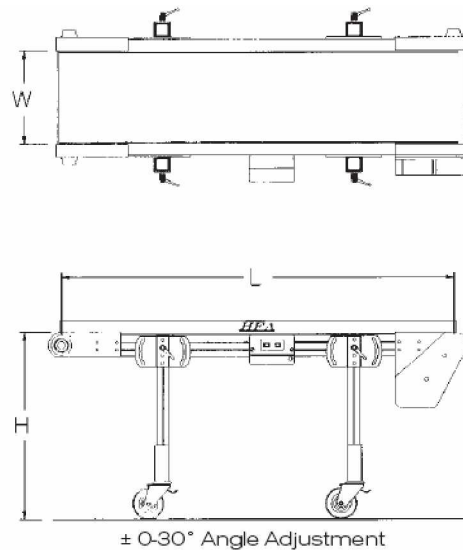

FEATURES (Models 2210 - 2240):

- Highest quality anodized extruded aluminum frame construction
- 2-Ply, polyurethane, FDA approved belt with endless splice (Available Belt Colors: White, Blue, Gray, Black, or Green)
- Fully recessed belt edges, both top and bottom of conveyor frame; Maximum gap between belt and side rails is less than .032" (Belt edges are surrounded in wear resistant plastic, which protects belt and helps eliminate contamination)
- Standard "SOFT-DROP ZONE" to cushion product fall and resist bouncing (slider-bed also available)
- Anodized cast aluminum belt take-up and bearing housing securely holds 2 1/4" Dia. trapezoidal crown pulley with 3/4" steel shaft
- U.S. Manufactured premium quality 3/4" sealed; self aligning bearings
- Modular design allows for motor to be repositioned on any corner
- "CLEANROOM" COMPATIBLE...NO PAINTED COMPONENTS

N60 W14459 Kaul Avenue
Menomonee Falls, WI 53051
Phone: 262-703-0890
Fax: 262-703-0895
Email: sales@aquapoly.com
www.aquapoly.com



Belt Conveyors

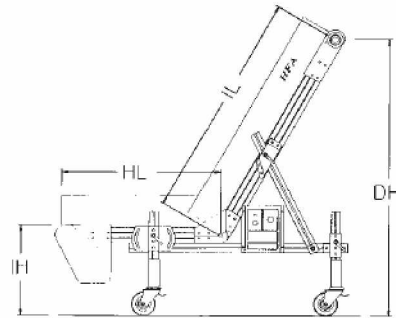
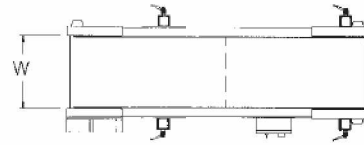

0° or 40°-60° Angle Adjustment

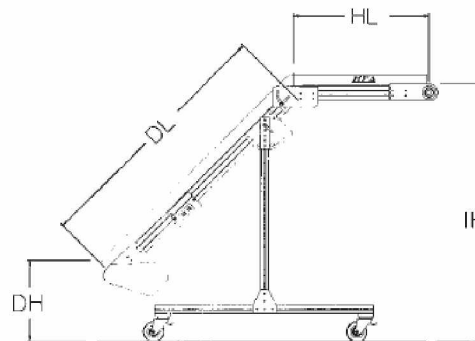
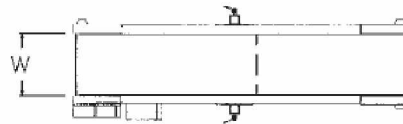

0-50° Angle Adjustment

FEATURES

- Manual motor starter with overload protection and OSHA lockout
- 115V/60Hz/1PH Motor
- Anodized extruded aluminum legs (Allow quick and infinite leg adjustments in height and location along entire length of frame...NO TOOLS REQUIRED)
- Totally enclosed drive and pulley system for operator safety...NO EXPOSED ROTATING PARTS
- 2" Tall anodized extruded aluminum side rails (5" Tall on all inclines)
- 4" Dia. Polyurethane, heavy duty, two-way toe locking, non-marking casters or adjustable height pads
- Delivered completely assembled, no assembly required
- EQUIPMENT IS MANUFACTURED TO RUN 24 HRS/DAY, 7 DAYS/WEEK
- 2 YEAR LIMITED WARRANTY

N60 W14459 Kaul Avenue
Menomonee Falls, WI 53051
Phone: 262-703-0890
Fax: 262-703-0895
Email: sales@aquapoly.com
www.aquapoly.com



Belt Conveyors

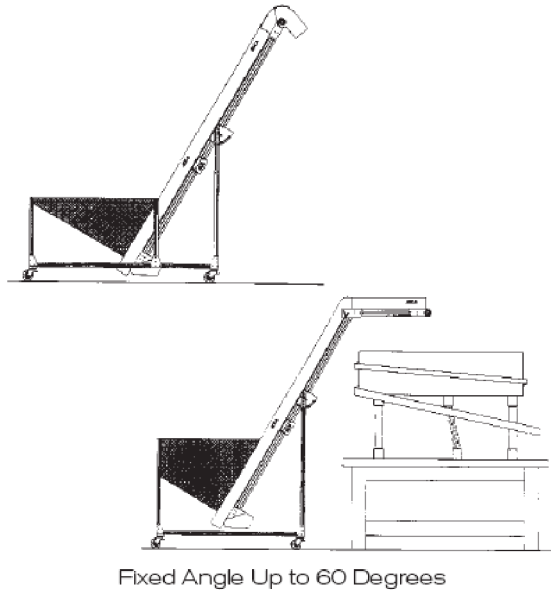
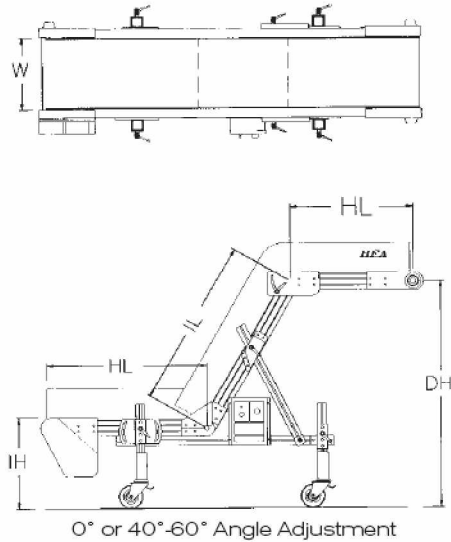

FEATURES (Models 2250 - 2260):

- Includes the same features listed for models 2210-2240
- 2250 conveyor is ideal to convey runners to grinders or parts to box filling applications or inspection tables
- 2260 conveyor is ideal to convey parts to automated assembly machine hoppers or feeder bowls
- Conveyor Options include any sized polished #304 stainless steel hoppers, motor starter controls with choice of photo eye sensors or paddle sensors, stainless steel discharge trays, and Lexan covers with cooling units...etc.

N60 W14459 Kaul Avenue
Menomonee Falls, WI 53051
Phone: 262-703-0890
Fax: 262-703-0895
Email: sales@aquapoly.com
www.aquapoly.com



Roller Conveyors

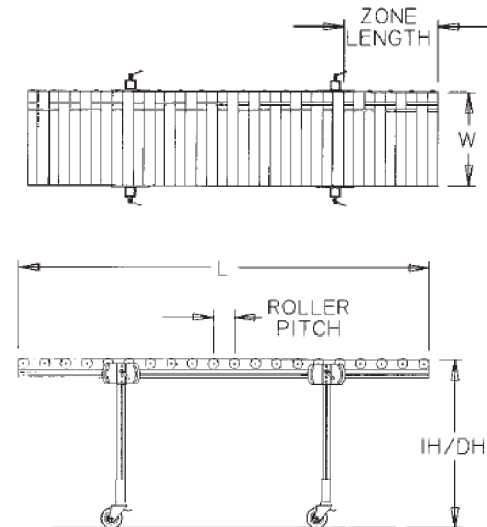
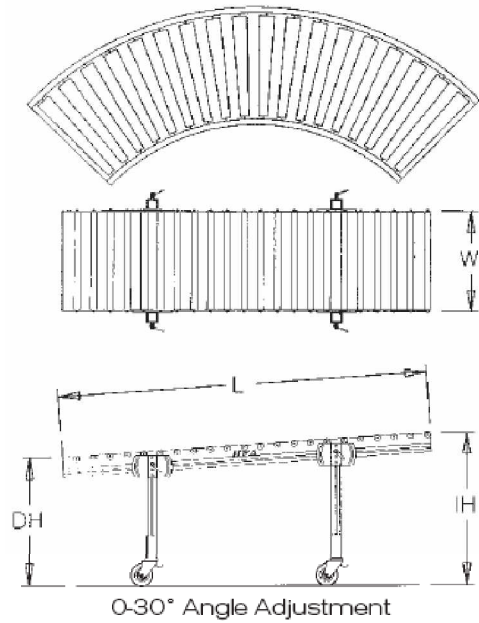

FEATURES (Models 2270 - 2280):

- 2270 utilizes 1.1" Dia. PVC rollers with precision steel ball bearings assembled on 1.5" or 3" centers
- Available in various widths or lengths, and at any elevation
- Gravity roller angles adjustable from ± 0 to 30 degrees
- 2280 is a DC powered roller conveyor with slaved roller zones, variable roller center distance, and variable zone length to accommodate various size boxes. Conveyor available with or without zero pressure accumulation

N60 W14459 Kaul Avenue
Menomonee Falls, WI 53051
Phone: 262-703-0890
Fax: 262-703-0895
Email: sales@aquapoly.com
www.aquapoly.com



Box Filling Systems



- Box/tote filling by weight or count.
- Custom sized to customer capacity.
- Multi-level units available.

Shown with optional Lexan cover.



FEATURES (Box Filling Systems):

- Custom made to accommodate customers size and quantity of either boxes, totes or bags
- Manufactured to fill boxes automatically by cycle count, weight, or weigh count
- Entire system operates on 110VAC (no compressed air required)
- User friendly controls with digital display of Job Name, Preset Weight, and Current Weight
- Systems can display weight in grams or lbs. Database allows for storage of multiple jobs
- Audible and visual alarms to signal system "Full" and/or "Empty"
- Weigh systems include "Trickle Feed" to allow accurate filling of containers

EQUIPMENT IS MANUFACTURED TO RUN 24 HRS/DAY, 7 DAYS/WEEK

N60 W14459 Kaul Avenue
Menomonee Falls, WI 53051
Phone: 262-703-0890
Fax: 262-703-0895
Email: sales@aquapoly.com
www.aquapoly.com



Box Filling Systems



Parallel Box - Fill System

**RT-Angle
90° Box - Fill System**



Rotary Bag / Box - Fill System

Parts Automation



Under - Press Product Chute

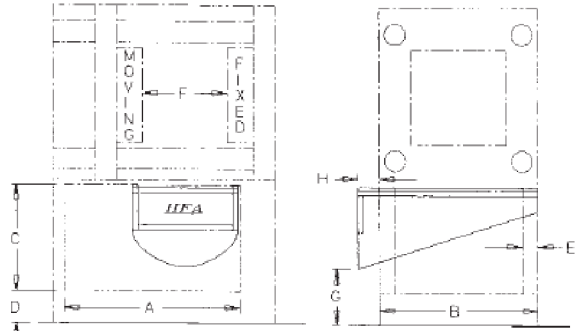

Portable Weigh Scale

FEATURES

- Aluminum frame construction.
- Stainless steel wash-down enclosure.
- Can count parts and/or weigh in units of Grams, Kilograms, or Pounds.
- Keypad for entering job data: Job number or name up to 16 alpha-numeric characters; avg. piece-weight; full-box quantity; full box weight.
- Set the tare value one time per job or automatically tare each individual box.
- Highly visible 4-line x 20 character vacuum fluorescent display. Displays job name, current quantity, under-accept-over, or number of completed boxes.
- Job database will store thousands of jobs making this the most powerful, user friendly and versatile portable scale on the market.



Rotary Work Table

FEATURES

- Aluminum frame construction.
- Variable speed control.
- Drive wheel with slip clutch and adjustable tensioning.
- Fully enclosed under-carriage.
- One inch rail along entire perimeter.
- Locking casters
- E-stop button.
- UHMW work surface ... others available upon request.

Automation Parts

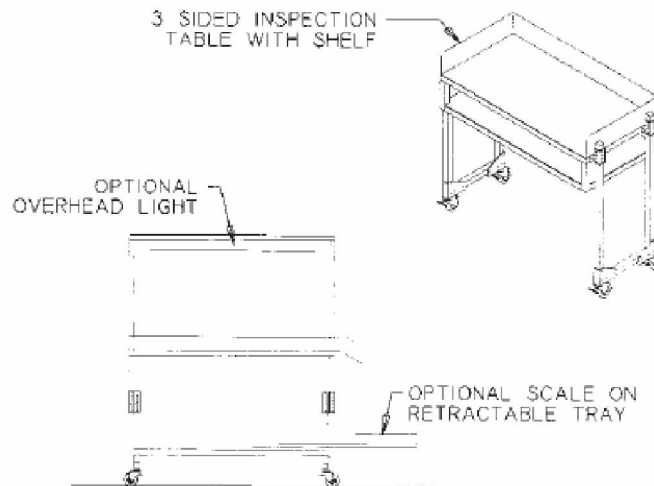
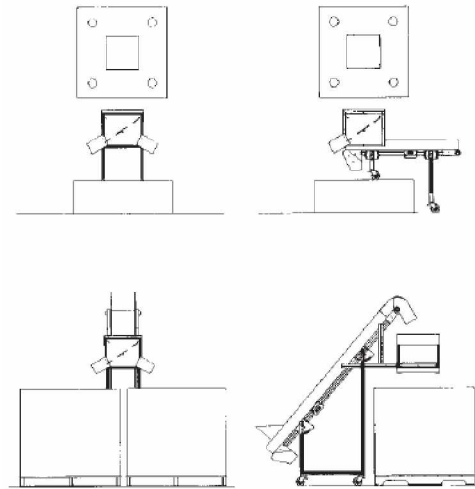

FEATURES (Diverters - Inspection Tables):

- Diverters are used to automatically “divert” reject shots, QC samples, and for filling two containers.
- They can be mounted to under press conveyors, incline conveyors or positioned beneath the mold.
- Standard features include stainless steel, UHMW and anodized aluminum construction with adjustable legs, pneumatic rotary actuator, 24VDC or 110VAC solenoid with filter/regulator.
- Inspection Tables are manufactured to your dimensions and requirements.
- Various options include but not limited to: Stainless steel and laminated work surfaces, inspection lights, scales, HEPA filtered blowers, static elimination, shelves, and cooling units.

N60 W14459 Kaul Avenue
Menomonee Falls, WI 53051
Phone: 262-703-0890
Fax: 262-703-0895
Email: sales@aquapoly.com
www.aquapoly.com



Robot Guarding



FEATURES

- Robot/conveyor guarding built to customer specifications.
- Optional doors with safety interlock switch.
- Stand alone units and/or mounted to conveyor.
- Portable and/or permanent.



Shown in "Down-position"



Shown in "Up-position"

FEATURES (V-Lifts):

- Highest quality anodized extruded aluminum frame construction.
- Pneumatic cylinder.
- Complete control package set in a NEMA 12-13 Hoffman enclosure.
- 110v – 24v – or dry contact signal.
- Aluminum platform with UHMW or Teflon insert.
- Choice of toe-locking casters and/or adjustable height pads.
- Infinitely **adjustable in-feed**, discharge height and tilt angle

N60 W14459 Kaul Avenue
Menomonee Falls, WI 53051
Phone: 262-703-0890
Fax: 262-703-0895
Email: sales@aquapoly.com
www.aquapoly.com



Cooling Conveyors



- Used with conveyors and/or work tables.
- Custom footprint and height.
- Stand alone or press wrap around.
- Fully enclosed under-carriage.
- Hard wall or soft wall.

FEATURES (Cleanrooms):

- Highest quality anodized extruded aluminum frame construction.
- Anti-static clear vinyl strip-curtains.
- HEPA filters, fluorescent lights and ABS filler squares make up the ceiling.
- Classification from 100 to 100,000.
- Portable or stationary.
- Choice of toe-locking casters and/or adjustable height pads.

N60 W14459 Kaul Avenue
Menomonee Falls, WI 53051
Phone: 262-703-0890
Fax: 262-703-0895
Email: sales@aquapoly.com
www.aquapoly.com

