

Surge Bins

Economical in plant storage bins are available in sizes ranging from 25 cu. ft. to 600 cu ft.. Large quantities of material can be stored using very little floor space. They can be filled or discharged using pneumatic or screw conveying equipment. There are many options available to adapt these bins to almost any material handling system. Check with us to see just how affordable bulk storage can be!



Standard Surge Bins with 18" Discharge Height for Screw Conveyor or Vacuum Take Away

Extended Legs for Gravity Discharge

Model No.	Description	Capacity	Discharge Height	Overall Height	Model No.	Discharge Height	Overall Height
44-4500	48"x48", 45° Hopper, 21" Sidewall	38 cu.ft.	18"	4'-9"	44-5500	60"	8'-3"
44-4600	48"x48", 45° Hopper, 33" Sidewall	54 cu.ft.	18"	5'-9"	44-5600	60"	9'-3"
44-4800	48"x48", 45° Hopper, 45" Sidewall	70 cu.ft.	18"	6'-9"	44-5800	60"	10'-3"
45-4500	60"x60", 45° Hopper, 24" Sidewall	70 cu.ft.	18"	5'-6"	45-5500	60"	9'-0"
45-4600	60"x60", 45° Hopper, 36" Sidewall	95 cu.ft.	18"	6'-6"	45-5600	60"	10'-0"
45-4800	60"x60", 45° Hopper, 60" Sidewall	145 cu.ft.	18"	8'-6"	45-5800	60"	12'-0"
45-4900	60"x60", 45° Hopper, 84" Sidewall	195 cu.ft.	18"	10'-6"	45-5900	60"	14'-0"
46-4800	72"x72", 45° Hopper, 52" Sidewall	192 cu.ft.	18"	8'-4"	46-5800	60"	11'-10"
46-4900	72"x72", 45° Hopper, 76" Sidewall	264 cu.ft.	18"	10'-4"	46-5900	60"	13'-10"
44-6500	48"x48", 60° Hopper, 22" Sidewall	47 cu.ft.	18"	5'-11"	44-7500	60"	9'-5"
44-6600	48"x48", 60° Hopper, 34" Sidewall	63 cu.ft.	18"	6'-11"	44-7600	60"	10'-5"
45-6600	60"x60", 60° Hopper, 22" Sidewall	75 cu.ft.	18"	6'-10"	45-7600	60"	10'-4"
45-6800	60"x60", 60° Hopper, 46" Sidewall	125 cu.ft.	18"	8'-10"	45-7800	60"	12'-4"
45-6900	60"x60", 60° Hopper, 70" Sidewall	175 cu.ft.	18"	10'-10"	45-7900	60"	14'-4"
46-6800	72"x72", 60° Hopper, 34" Sidewall	162 cu.ft.	18"	8'-9"	46-7800	60"	12'-3"
46-6900	72"x72", 60° Hopper, 58" Sidewall	234 cu.ft.	18"	10'-9"	46-7900	60"	14'-3"

N60 W14459 Kaul Avenue
 Menomonee Falls, WI 53051
 Phone: 262-703-0890
 Fax: 262-703-0895
 Email: sales@aquapoly.com
www.aquapoly.com



Surge Bins

Standard Features:

- | 3 x 3 x 1/4 Angle Legs
- | 12 ga. Hopper
- | Bolt Down Foot Pads
- | Loader Mounting Cut Out (250 lbs. Max)
- | 1/3 Hinged Covers
- | Air Box Discharge Flange (16.25" x 16.25")
- | Ensign Blue Epoxy (Outside Only)

Optional Features:

- | 12" x 12" Slide Gate
- | 6" x 6" Discharge Adaptor
- | 6" Slide Gate
- | 4" Discharge Spout w/ Slide Gate
- | Filter in Cover
- | 1 1/4" Pipe Stub in Hopper
- | Level Control
- | 4" Window
- | Platform w/ Ladder
- | Epoxy Paint Inside
- | Custom Paints and Matching Colors

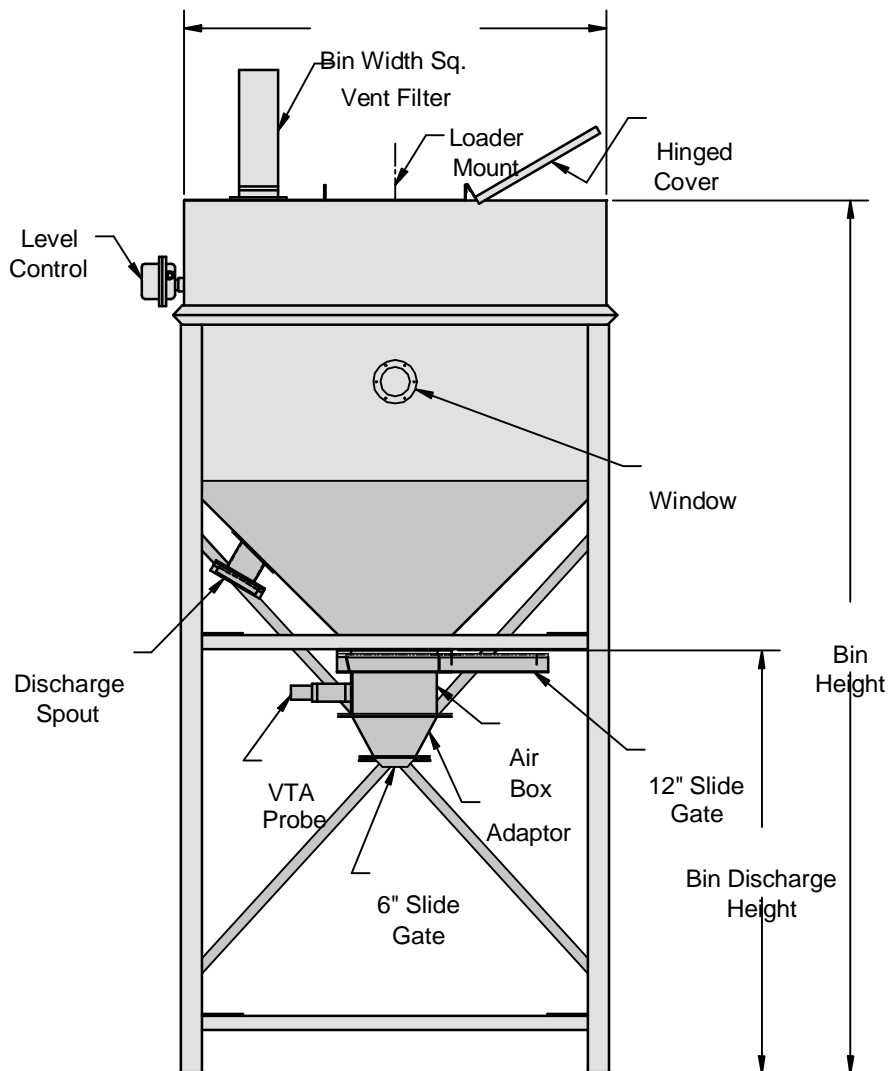

N60 W14459 Kaul Avenue
 Menomonee Falls, WI 53051
 Phone: 262-703-0890
 Fax: 262-703-0895
 Email: sales@aquapoly.com
 www.aquapoly.com



Pneumatic Components

Vacuum Probes

Horizontal, Aluminum with adjustable air flow

- 82-5001 1.5" Probe
- 82-5002 2" Probe
- 82-5003 2.5" Probe
- 82-5004 3" Probe

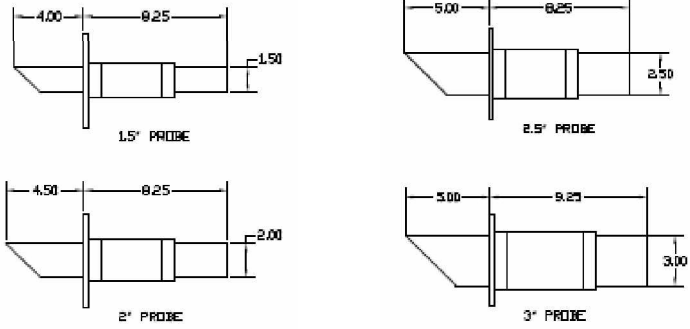
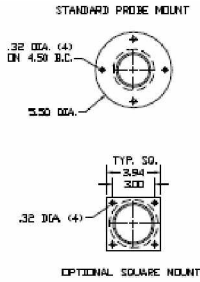

Aluminum Vacuum Takeway Boxes

- 82-5112 1 Port, V Bottom
- 82-5101 1 Port, Flat Bottom
- 82-5102 2 Port, Flat Bottom
- 82-5104 4 Port, Flat Bottom
- 82-5105 6 Port, Flat Bottom
- 82-5152 Port Cover Plate

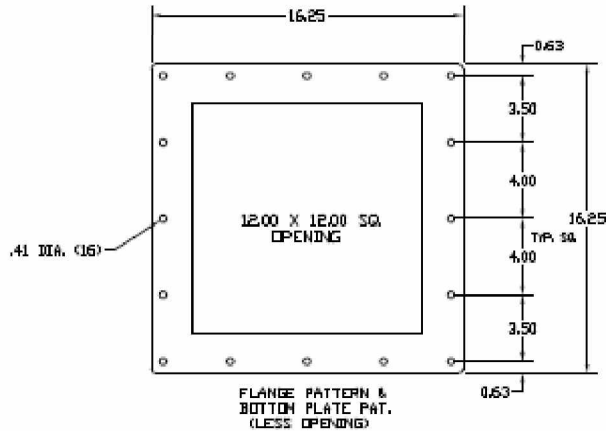

Accessories

- 00-0210 12" Manual Slide Gate
- 00-0220 12" Rack & Pinion Slide Gate

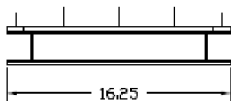
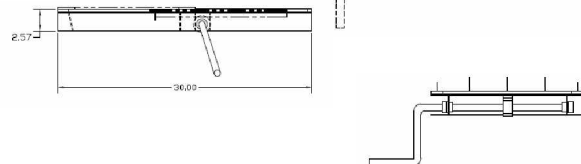
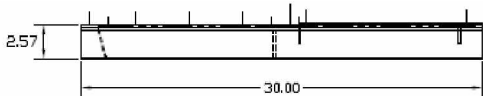
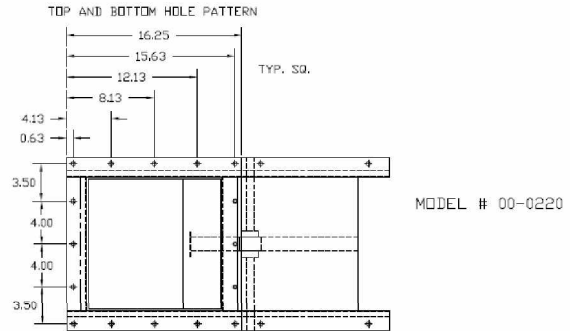
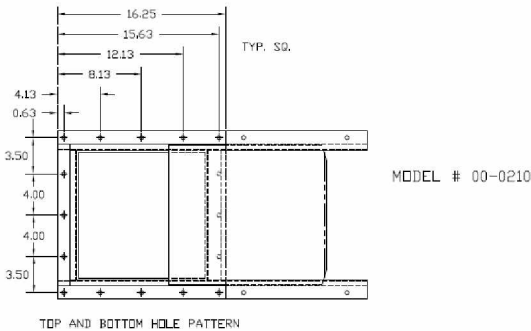

N60 W14459 Kaul Avenue
 Menomonee Falls, WI 53051
 Phone: 262-703-0890
 Fax: 262-703-0895
 Email: sales@aquapoly.com
 www.aquapoly.com



N60 W14459 Kaul Avenue
Menomonee Falls, WI 53051
Phone: 262-703-0890
Fax: 262-703-0895
Email: sales@aquapoly.com
www.aquapoly.com



Porta-Stor Bins

Porta-Stor Bins were designed to replace Gaylords in your bulk material handling system. You can buy material in bulk and use Bins to distribute the material throughout your plant. These 44" square, stackable bins can be filled using Surge Bins, Screw Conveyors or Hydraulic Dumpers. They can be discharged through the 4" bottom slide gate or the optional 4 way vacuum ports.

These bins are built to last with a 14ga steel hopper and 2" x 1/4" angle frame. They are coated with abrasion resistant epoxy inside and out.

We can custom design these bins with steeper side walls and larger slide gates for less flowable material. They can be made larger or smaller, from aluminum or stainless steel. Look over our the list of features and options on the back page and let us build a bin to suit your needs.



All Ensign Equipment Inc. products carry a TWO YEAR warranty covering defects in manufacture, workmanship and components. Also all STANDARD products are covered by the Ensign Advantage, a 30 day trial period guaranteeing customer satisfaction!

Porta-Stor Bins

Standard Features:

- | Two Way Fork Channels
- | Flared Stacking Pads
- | 14 ga Hopper
- | 2" x 1/4" Angle Legs
- | 4" Slidegate
- | Blue Epoxy

Optional Features:

- | Four Way Vacuum Ports
- | Hinged Covers
- | Pallet Jack Entries
- | Four Way Fork Channels
- | Foot Pads
- | 4" Casters (2- Rigid, 2- Swivel)
- | One Piece Lay-On Cover
- | 1/3 - 2/3 Cover with Loader Mounting
- | Lexan Card Holder
- | Stainless Steel Construction
- | Custom Paints and Matching Colors

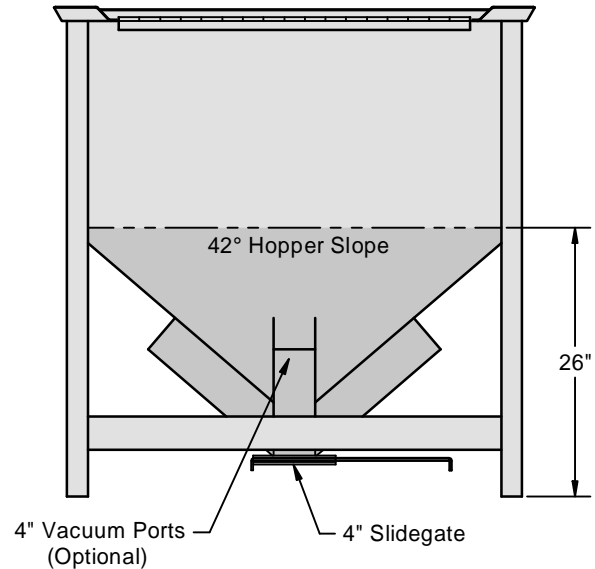
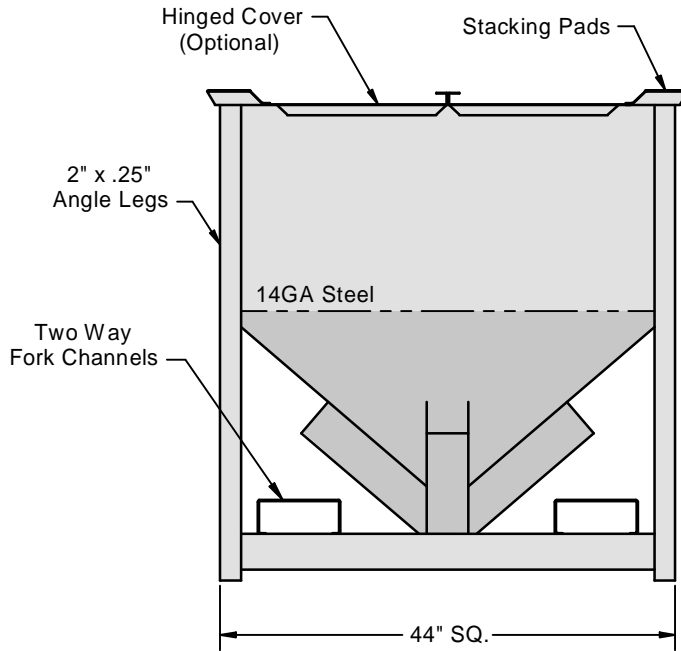

Model No.	Description	Height	Height w/ Vacuum Ports
40-2000	Porta - Stor Bin, 20 cu. ft. Cap.	32"	36"
40-3000	Porta - Stor Bin, 30 cu. ft. Cap.	42"	46"
40-4000	Porta - Stor Bin, 40 cu. ft. Cap.	52"	56"
40-5000	Porta - Stor Bin, 50 cu. ft. Cap.	62"	66"
40-6000	Porta - Stor Bin, 60 cu. ft. Cap.	72"	76"

N60 W14459 Kaul Avenue
 Menomonee Falls, WI 53051
 Phone: 262-703-0890
 Fax: 262-703-0895
 Email: sales@aquapoly.com
www.aquapoly.com



Portable Storage Bins for Sluggish Material

Portable Storage Bins were designed to replace Gaylords in your bulk material handling system. You can buy material in bulk and use Portable Storage Bins to distribute the material throughout your plant. These 44" square, stackable bins can be filled using Surge Bins, Screw Conveyors or Hydraulic Dumpers.

Our 60 Deg. Bins will handle most regrind material that is of normal bulk density (30 to 40 lbs. per cu. ft.). Our Drop Bottom Bins will handle fluff material 10 to 30 lbs per cu. ft. and are ideal for use with our Live Bottom Power Hoppers.



60 Deg. Portable Storage Bin



Drop Bottom Bin

All of these bins are built to last with a 14ga steel hopper and 2" x 1/4" angle frame. They are painted with an abrasion resistant epoxy paint inside and out.

We can custom design bins with the features you want. Look over our the list of features and options on the back page, then let us build you bins that will suit your needs.

All Ensign Equipment Inc. products carry a TWO YEAR warranty covering defects in manufacture, workmanship and components. Also all STANDARD products are covered by the Ensign Advantage, a 30 day trial period Guaranteeing customer satisfaction!

Portable Storage Bins for Sluggish Material

Portable 60 deg. Bins

Standard Features:

- | Two Way Fork Channels
- | Flared Stacking Pads
- | 14 ga. Hopper
- | 2" x 1/4" Angle Legs
- | 8" Slide Gate
- | 60 deg. Hopper Slope
- | Painted Ensign Blue Epoxy

Optional Features:

- | One or Two Way Vacuum Ports
- | Hinged Covers
- | Pallet Jack Entries
- | Four Way Fork Channels
- | Foot Pads
- | 4" Casters (2- Rigid, 2- Swivel)
- | One Piece Lay-On Cover
- | 1/3 - 2/3 Cover with Loader Mounting
- | Lexan Card Holder
- | Stainless Steel Construction
- | Custom Sizes and Capacities
- | Custom Paints and Matching Colors

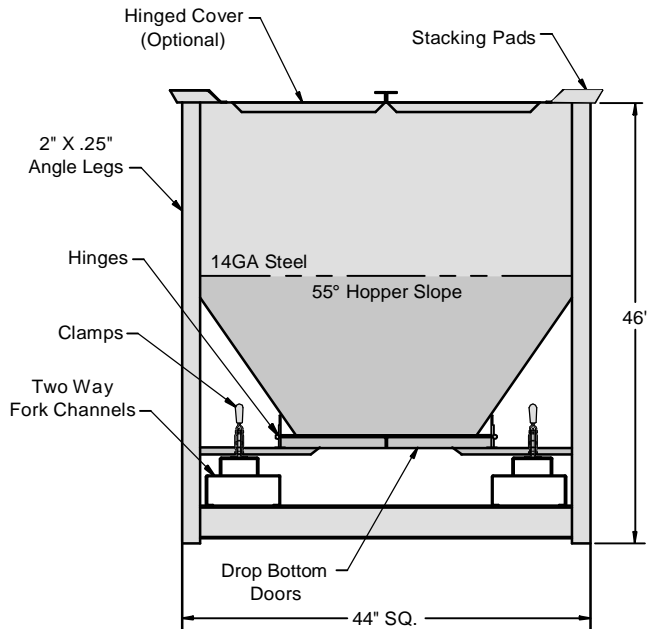
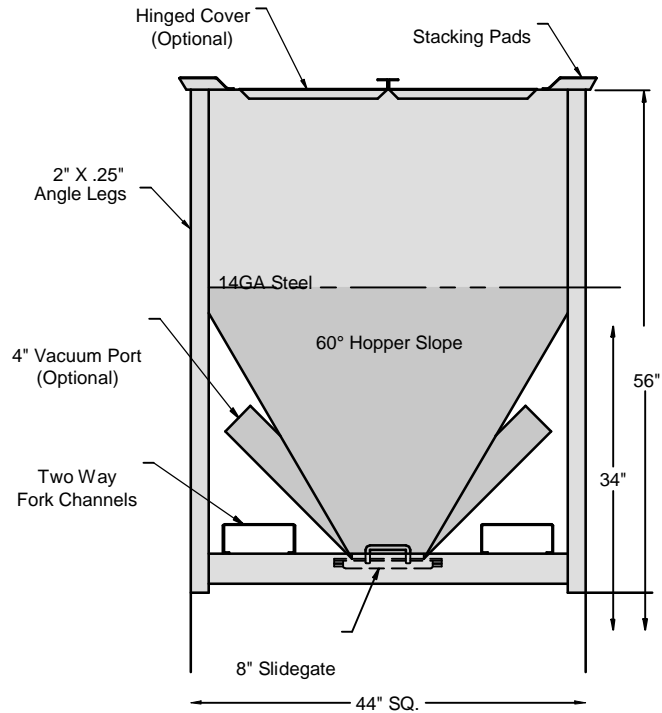

Portable Drop Bottom Bins

Standard Features:

- | Two Way Fork Channels
- | Flared Stacking Pads
- | 14 ga Hopper
- | 2" x 1/4" Angle Legs
- | Drop Bottom Gate 20" x 28" Opening
- | Hopper Slope, 66 & 55 deg.
- | Painted Ensign Blue Epoxy

Optional Features:

- | Hinged Covers
- | Foot Pads
- | 4" Casters (2- Rigid, 2- Swivel)
- | One Piece Lay-On Cover
- | Lexan Card Holder
- | Stainless Steel Construction
- | Custom Sizes and Capacities
- | Custom Paints and Matching Colors

Model No.	Description	Height
40-3300	60 Deg. Porta-Stor Bin, 30 cu. ft. Cap.	56"
40-3400	Drop Bottom Porta-Stor Bin, 30 cu. ft. Cap.	46"

N60 W14459 Kaul Avenue
 Menomonee Falls, WI 53051
 Phone: 262-703-0890
 Fax: 262-703-0895
 Email: sales@aquapoly.com
www.aquapoly.com



Ground Entry Pneumatic Gaylord Tilter

Model 10-6000

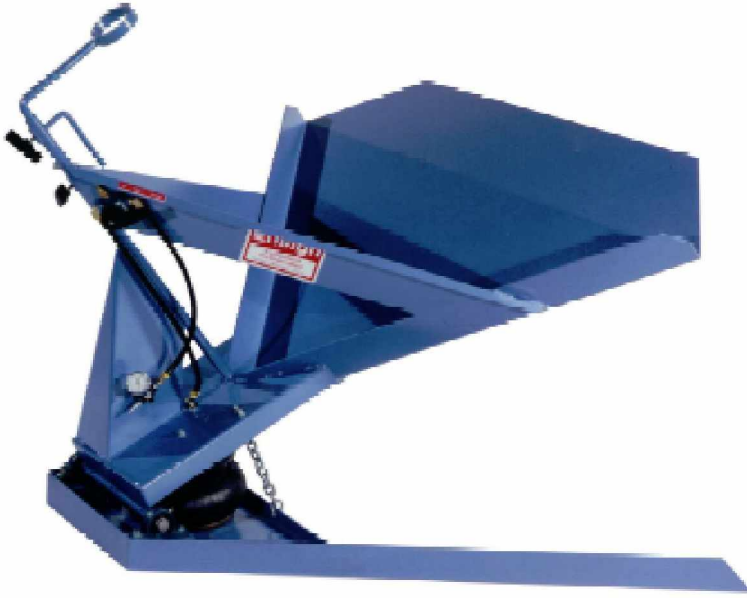

The Ground Entry Pneumatic Gaylord Tilter is designed to assist in the vacuum unloading of gaylord containers. The automatic tilting feature allows complete removal of material from the container with little or no assistance from your operator. The adjustable regulator permits setting initial lift at any desired weight: this unit will lift 800# with only 80psi. air pressure! Normal operation is to begin tilting action when the box is around half empty. Ensign Equipment Inc. Tilt Tables are durable and easy to maintain. We use heavy duty pillow block bearings to ensure smooth controlled pivoting. Our seven gauge deck along with its sound structural design make it durable enough to withstand years of abuse. These units will reduce labor cost by freeing your operator from tending to raw material flow. They also reduce material waste with the effortless, complete emptying of your container!

All Ensign Equipment Inc. products carry a TWO YEAR warranty covering defects in manufacture, workmanship and components. Also all STANDARD products are covered by the Ensign Advantage, a 30 day trial period guaranteeing customer satisfaction!

N60 W14459 Kaul Avenue
Menomonee Falls, WI 53051
Phone: 262-703-0890
Fax: 262-703-0895
Email: sales@aquapoly.com
www.aquapoly.com



Ground Entry Pneumatic Gaylord Tilter

Standard Features:

- | Automatic or Manual Tilt Action
- | Hand Level Controlled
- | Flow Control to adjust operating speed
- | Seven Gauge Steel Deck
- | Adjustable Height Vacuum Wand Holder
- | 1" Pillow Block Pivot Bearing
- | Double Convoluted Industrial Air Bag
- | 45 Degree Tilt Angle
- | Ensign Blue Epoxy

Optional Features:

- | Foot Pedal Control Valve
- | Pneumatic Turbine Vibrator w/ Controls
- | 110V Electric Vibrator w/ Controls
- | Custom Paints and Matching Colors

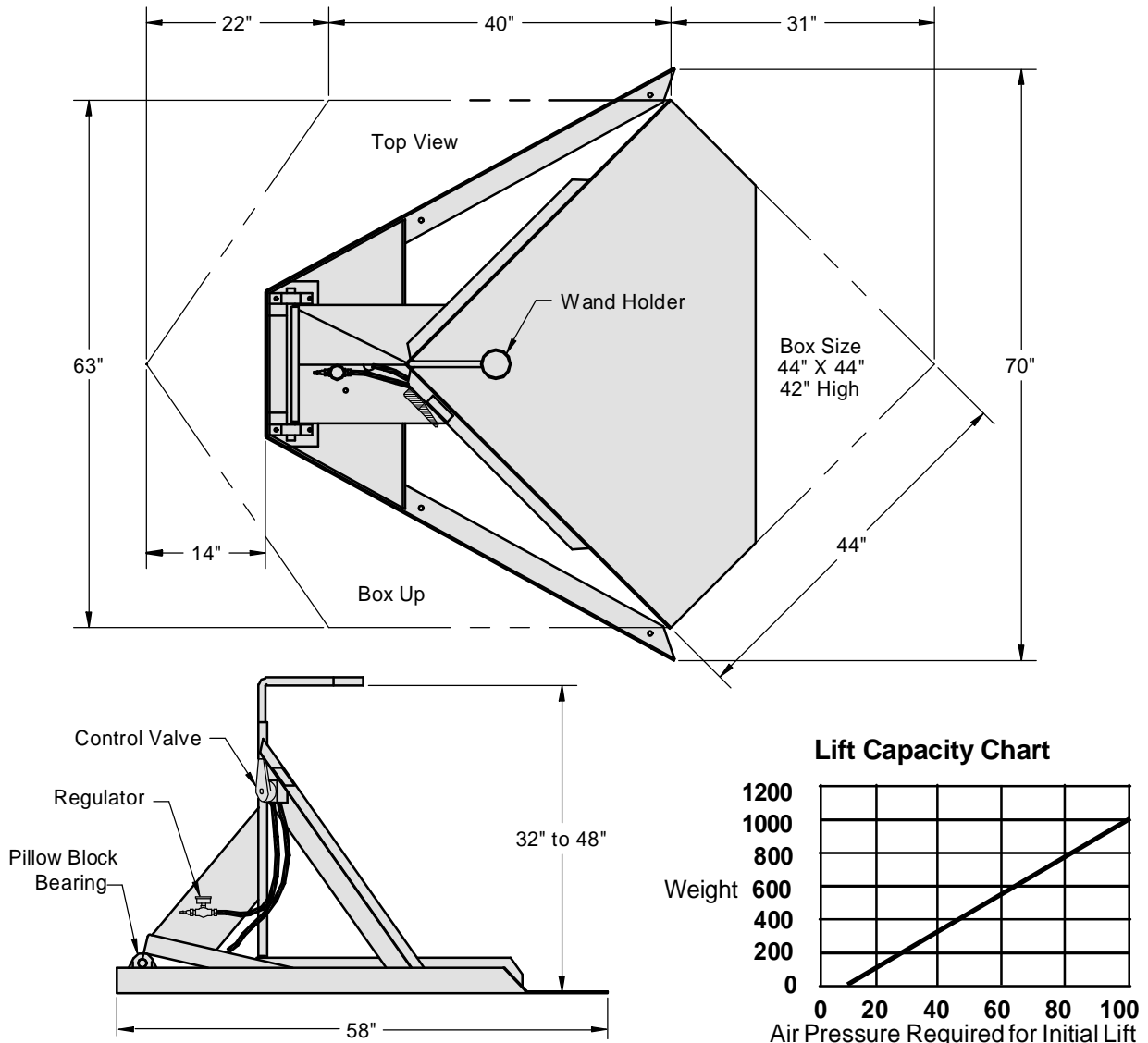

N60 W14459 Kaul Avenue
 Menomonee Falls, WI 53051
 Phone: 262-703-0890
 Fax: 262-703-0895
 Email: sales@aquapoly.com
www.aquapoly.com



Premier Ground Entry Gaylord Tilter



The Premier Ground Entry Gaylord Tilter is designed to assist in the vacuum unloading of Gaylord containers. The automatic tilting feature allows complete removal of material from the container with little or no assistance from your operator. The adjustable regulator permits setting initial lift at any desired weight: this unit will lift 1000# with only 80psi. air pressure! Normal operation is to begin tilting action when the box is around half empty. Ensign Equipment Tilt Tables are durable and easy to maintain. We use heavy duty 1" flange bearings to ensure smooth controlled pivoting. Our seven gauge deck along with its sound structural design make it durable enough to withstand years of abuse. These units will reduce labor cost by freeing your operator from tending his raw material flow. They also reduce material waste with the effortless, complete emptying of your container!

All Ensign Equipment Inc. products carry a TWO YEAR warranty covering defects in manufacture, workmanship and components. Also all STANDARD products are covered by the Ensign Advantage, a 30 day trial period guaranteeing customer satisfaction!

N60 W14459 Kaul Avenue
Menomonee Falls, WI 53051
Phone: 262-703-0890
Fax: 262-703-0895
Email: sales@aquapoly.com
www.aquapoly.com



**QUA POLY
EQUIPMENT CO.**

Premier Ground Entry Gaylord Tilter

Standard Features:

- | Automatic or Manual Tilt Action
- | Hand Level Controlled
- | Flow Control to adjust down cycle speed
- | Seven Gauge Steel Deck
- | Adjustable Height Vacuum Wand Holder
- | 1" Flanged Pivot Bearing
- | Double Convuluted Industrial Air Bag
- | 45 Degree Tilt Angle
- | Ensign Blue Epoxy

Optional Features:

- | Foot Pedal Control Valve
- | Pneumatic Turbine Vibrator w/ Controls
- | Custom Paints and Matching Colors

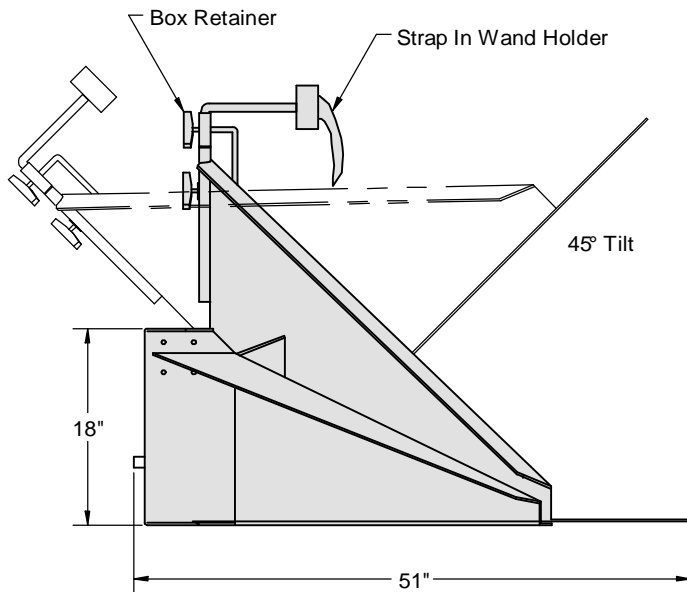
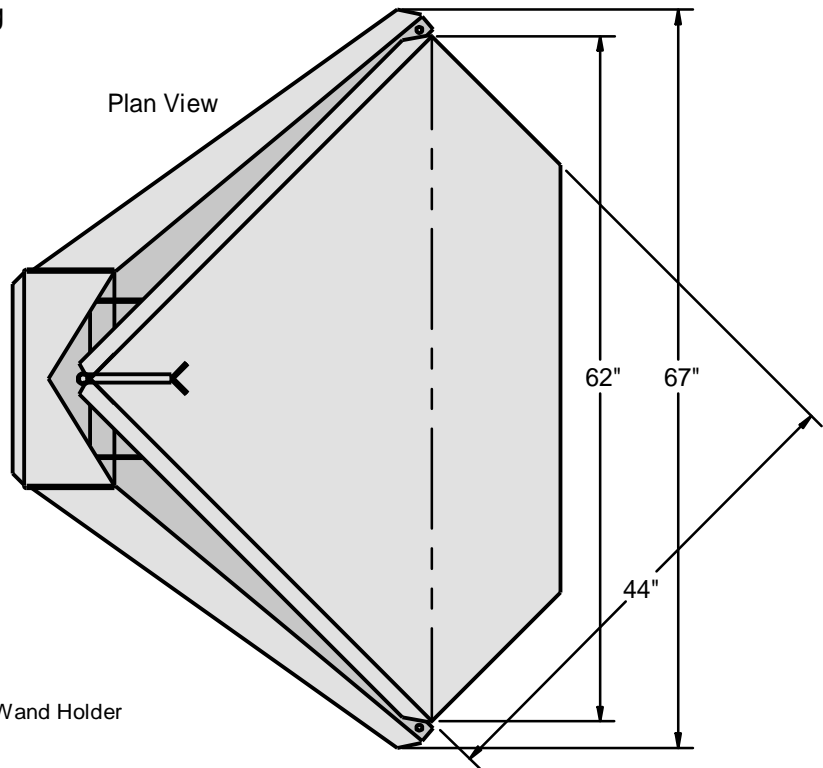

Lift Capacity Chart

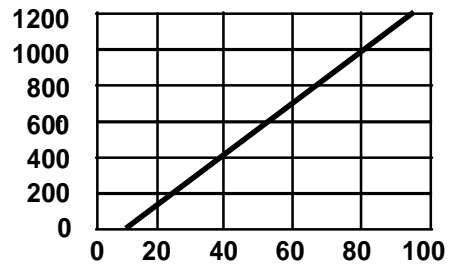

Air Pressure Required for Initial Lift

N60 W14459 Kaul Avenue
 Menomonee Falls, WI 53051
 Phone: 262-703-0890
 Fax: 262-703-0895
 Email: sales@aquapoly.com
www.aquapoly.com



Pneumatic Gaylord Tilter



Model 10-5000

The Pneumatic Gaylord Tilter is designed to assist in the vacuum unloading of Gaylord containers. The automatic tilting feature allows complete removal of material from the container with little or no assistance from your operator. The adjustable regulator permits setting initial lift at any desired weight: this unit will lift 1400# with only 80psi. air pressure! Normal operation is to begin tilting action when the box is around half empty. Ensign Equipment Tilt Tables are durable and easy to maintain. We use heavy duty pillow block bearings to ensure smooth controlled pivoting. Our ten gauge deck is reinforced with structural steel to make it durable enough to withstand years of abuse. These units will reduce labor cost by freeing your operator from tending his raw material flow. They also reduce material waste with the effortless, complete emptying of your container!

All Ensign Equipment Inc. products carry a TWO YEAR warranty covering defects in manufacture, workmanship and components. Also all STANDARD products are covered by the Ensign Advantage, a 30 day trial period guaranteeing customer satisfaction!

N60 W14459 Kaul Avenue
Menomonee Falls, WI 53051
Phone: 262-703-0890
Fax: 262-703-0895
Email: sales@aquapoly.com
www.aquapoly.com



**QUA POLY
EQUIPMENT CO.**

Pneumatic Gaylord Tilter

Standard Features:

- | Automatic or Manual Tilt Action
- | Hand Level Controlled
- | Flow Control to adjust operating speed
- | Ten Gauge Steel Deck
- | Adjustable Height Vacuum Wand Holder
- | 1" Pillow Block Pivot Bearing
- | Double Convoluted Industrial Air Bag
- | 45 Degree Tilt Angle
- | Blue Epoxy

Optional Features:

- | Foot Pedal Control Valve
- | Pneumatic Turbine Vibrator w/ Controls
- | 110V Electric Vibrator w/ Controls
- | Custom Paints and Matching Colors

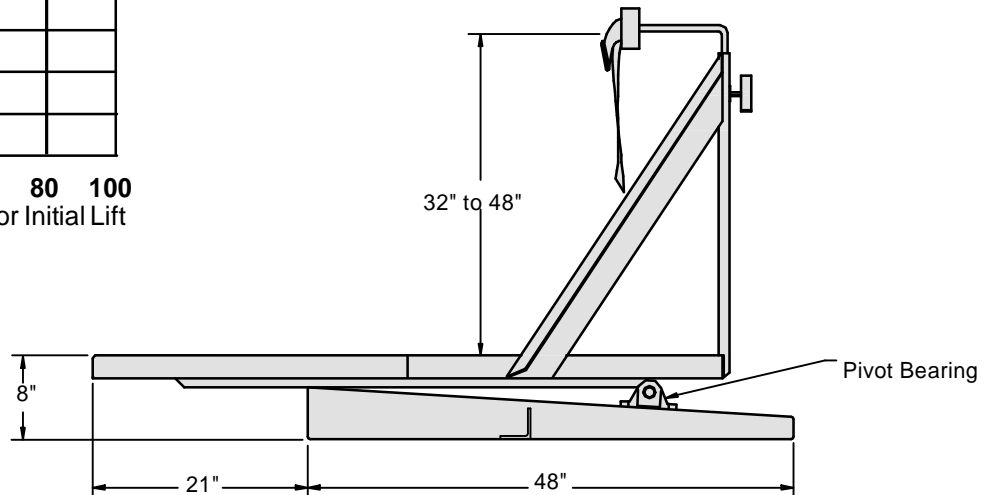
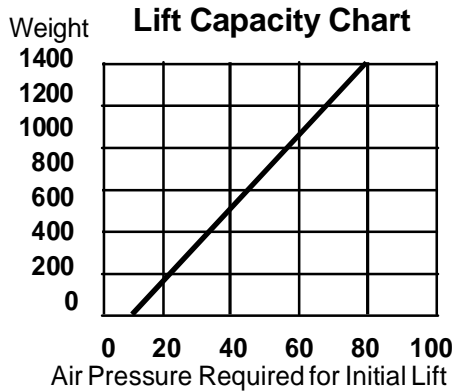
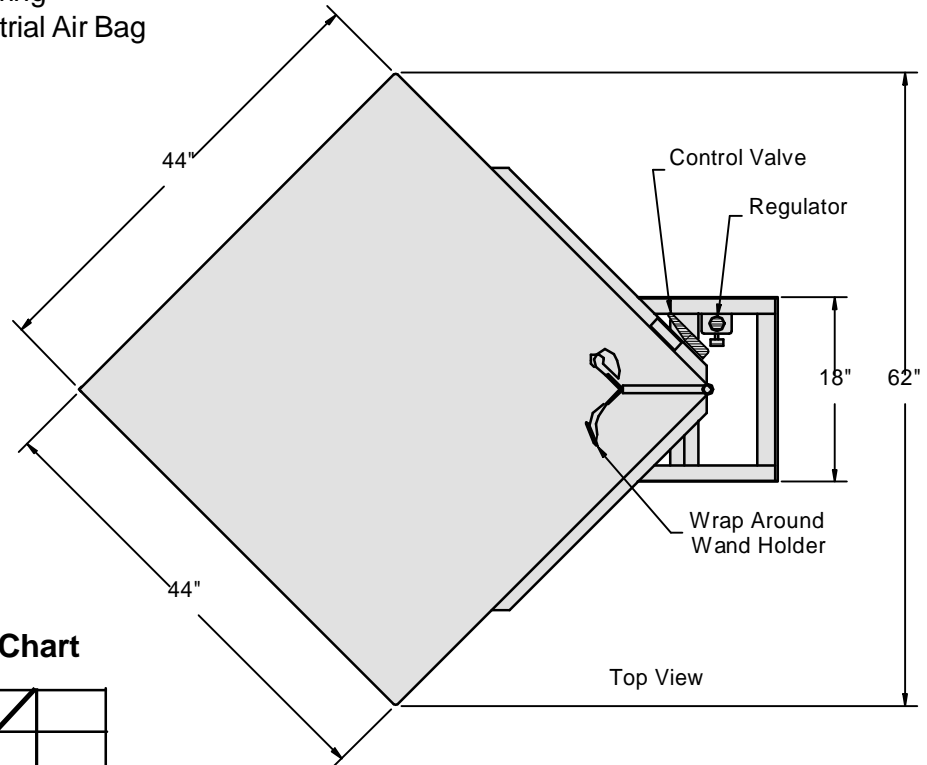

Side Tilt Parts Unloader

All Ensign Equipment Inc. products carry a TWO YEAR warranty covering defects in manufacture, workmanship and components. Also all STANDARD products are covered by the Ensign Advantage, a 30 day trial period guaranteeing customer satisfaction!

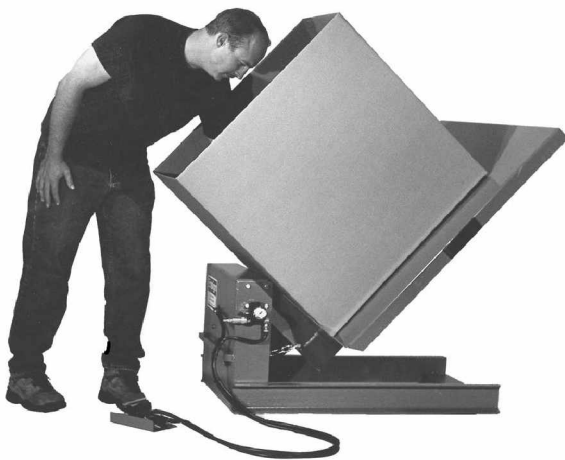

Model 10-7050

The Ensign Equipment SideTilt Parts Unloader is designed to ease the back breaking task of unloading boxes by hand. The automatic tilting action allows the user to easily remove parts from Gaylord sized containers. The adjustable regulator permits setting initial lift at any desired weight. This unit will lift 1400# with only 80psi air pressure! Ensign Equipment Parts Unloaders are durable and easy to maintain. We use heavy duty flange bearings to ensure smooth controlled pivoting. Our ten gauge top deck is reinforced with structural steel to make it durable enough to stand years of abuse.

N60 W14459 Kaul Avenue
Menomonee Falls, WI 53051
Phone: 262-703-0890
Fax: 262-703-0895
Email: sales@aquapoly.com
www.aquapoly.com



Side Tilt Parts Unloader

Standard Features:

- | Automatic or Manual Tilt Action
- | Foot Pedal Controlled
- | Flow Control to adjust Operating Speed
- | 10 Gauge Steel Deck
- | 4 Bolt Flange Bearings, 1"
- | Double Convoluted Industrial Air Bag
- | 45 Deg. Tilt Angle
- | Blue Epoxy

Optional Features:

- | Remote Hand Lever Control Valve
- | Pneumatic Turbine Vibrator with Controls
- | 110v Electric Vibrator with Controls
- | Custom Paints and Matching colors

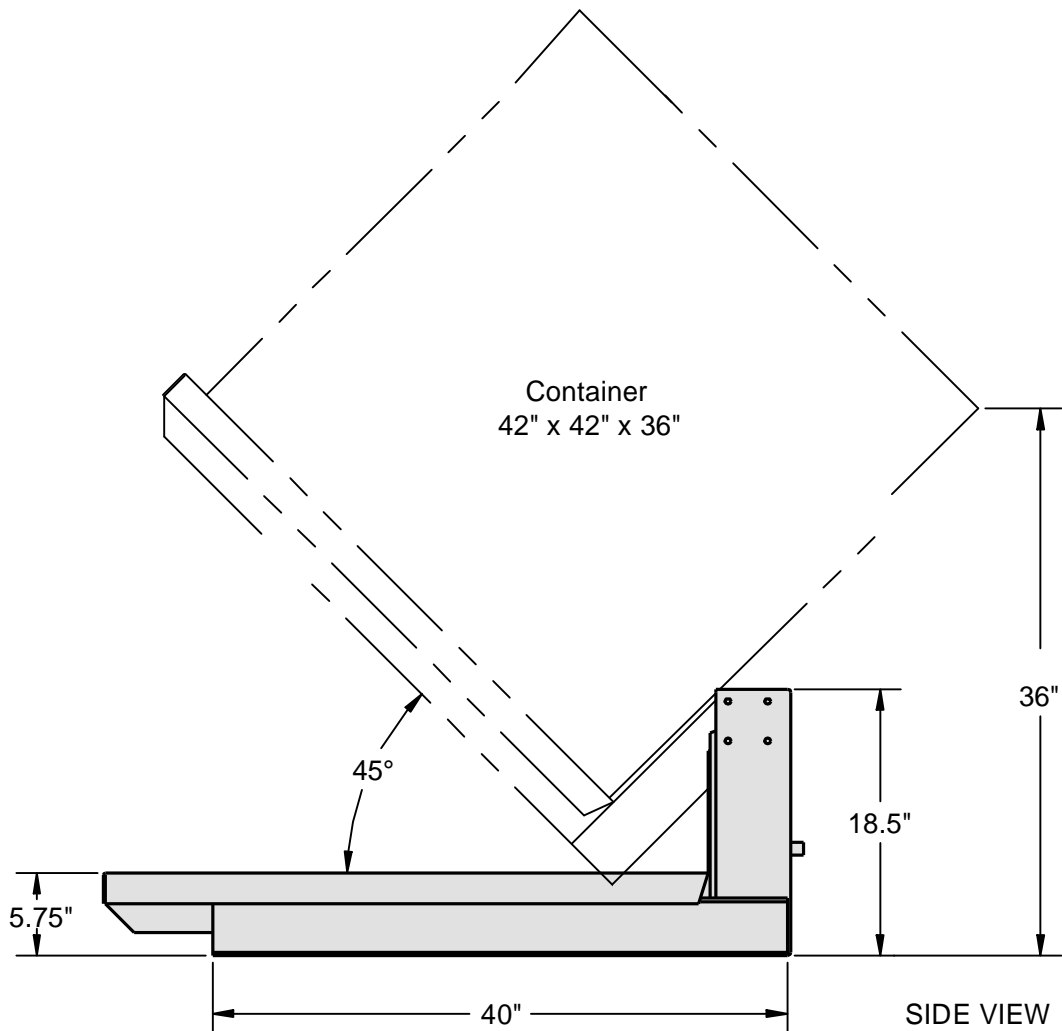

N60 W14459 Kaul Avenue
Menomonee Falls, WI 53051
Phone: 262-703-0890
Fax: 262-703-0895
Email: sales@aquapoly.com
www.aquapoly.com



Hydraulic Box Dumper

The Hydraulic Box Dumper is a durable, well built unit designed for industrial applications. It features greaseable sleeve bearings at the main pivot and bronze sleeve bearings at the top cylinder mounts. We use a proven 1.5 h.p. hydraulic package with easy to service components and a separate oil reservoir.

Designed for increased safety, the unit features a wider clearance between the frame and bucket to reduce possible pinch points. The unit can be stopped anywhere in the up - down cycle simply by releasing the push button control.

Our standard units all have 2500# lift capacity and a gravity return. Units are powered by a pair of 2" bore, 2" rod, ram style cylinders. Special dust control and other hooded units use cylinders with a 3" bore and are powered on both the up and down cycles.



See back page for additional specifications.

All Ensign Equipment Inc. products carry a TWO YEAR warranty covering defects in manufacture, workmanship and components. Also all STANDARD products are covered by the Ensign Advantage, a 30 day trial period guaranteeing customer satisfaction!

Hydraulic Box Dumper

Standard Features:

- | Bucket Rotation 135 deg.
- | Motor 1.5 h.p.
- | NEMA 12 Electrical Enclosure
- | Hydraulic Cylinders w/ 24" stroke, 2" bore, 2" rod
- | Adjustable Retaining Bar 32" to 48"
- | Up Cycle Complete, Limit Switch
- | Down Cycle Flow Control Valve
- | Cycle Time- 30 sec. Up, 15 sec. Down
- | Greasable Sleeve Type Main Bearings
- | Ensign Blue Epoxy

Optional Features:

- | Gaylord Entry Guides
- | Velocity Fuse, (catches bucket in case of hydraulic rupture)
- | Custom Size and Shape Buckets
- | Dust Hood with Discharge Hatch
- | Dust Containment Doors on Bucket
- | Dumper Stands 12" to 72"
- | Floor Grate in Bucket
- | Double Acting Hydraulics
- | Explosion Proof Electrical
- | Stainless Steel Chute Liner
- | Stainless Steel Construction
- | Custom Paints and Matching Colors

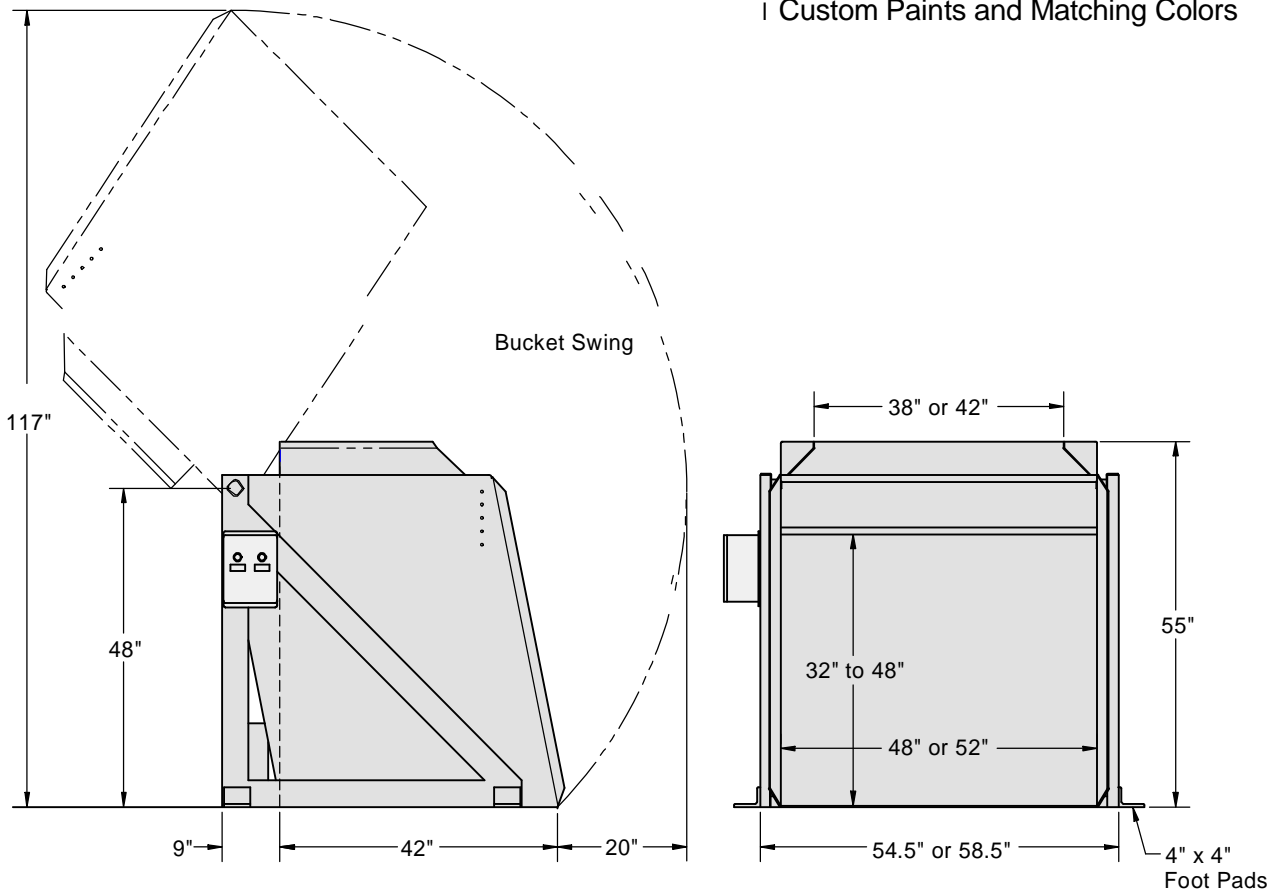

Model No.	Description
31-2500	Dumper, Rear Load, 2500 lbs, Cap., 3 Phase, 48" Wide Bucket
31-2550	Dumper, Rear Load, 2500 lbs. Cap., Single Phase, 48" Wide Bucket
31-5200	Dumper, Rear Load, 2500 lbs. Cap., 3 Phase, 52" Wide Bucket
31-5250	Dumper, Rear Load, 2500 lbs. Cap., Single Phase, 52" Wide Bucket

N60 W14459 Kaul Avenue
 Menomonee Falls, WI 53051
 Phone: 262-703-0890
 Fax: 262-703-0895
 Email: sales@aquapoly.com
www.aquapoly.com



Premier Hydraulic Box Dumper

The Premier Hydraulic Box Dumper is designed and built for continuous operation. It features 2" piloted roller bearings at the main pivot and bronze sleeve bearings at the top cylinder mounts. We use a proven 1.5 h.p. hydraulic package with easy to service components and a separate oil reservoir.

Designed for increased safety, this unit has solid side panels on the frame and a wider clearance between the frame and bucket to eliminate pinch points. The unit can be stopped anywhere in the up and down cycle simply by releasing the push button control.

Our standard units all have 2500# lift capacity and a gravity return. Units are powered by a pair of 2" bore, 2" rod, ram style cylinder. Special dust control and other hooded units use cylinders with a 3" bore and are powered on both the up and down cycles.



See back page for additional specifications.

All Ensign Equipment Inc. products carry a TWO YEAR warranty covering defects in manufacture, workmanship and components. Also all STANDARD products are covered by the Ensign Advantage, a 30 day trial period guaranteeing customer satisfaction!

N60 W14459 Kaul Avenue
Menomonee Falls, WI 53051
Phone: 262-703-0890
Fax: 262-703-0895
Email: sales@aquapoly.com
www.aquapoly.com

**QUA POLY
EQUIPMENT CO.**

Premier Hydraulic Box Dumper

Standard Features:

- | Bucket Rotation 135 deg.
- | Motor 1.5 h.p.
- | NEMA 12 Electrical Enclosure
- | Hydraulic Cylinders w/ 24" stroke, 2" bore, 2" rod
- | Adjustable Retaining Bar 32" to 48"
- | Up Cycle Completion, Limit Switch
- | Down Cycle Flow Control Valve
- | Cycle Time- 30 sec. Up, 15 sec. Down
- | Replaceable Pivot Bearings
- | Ensign Blue Epoxy

Optional Features:

- | Velocity fuse, (catches bucket in case of hydraulic rupture)
- | Gaylord Entry Guides
- | Custom Size and Shape Buckets
- | Dust Hood with Discharge Hatch
- | Dust Containment Doors on Bucket
- | Dumper Stands 12" to 72"
- | Floor Grate in Bucket
- | Double Acting Hydraulics
- | Explosion Proof Electrical
- | Stainless Steel Chute Liner
- | Stainless Steel Construction
- | Custom Paints and Matching Colors

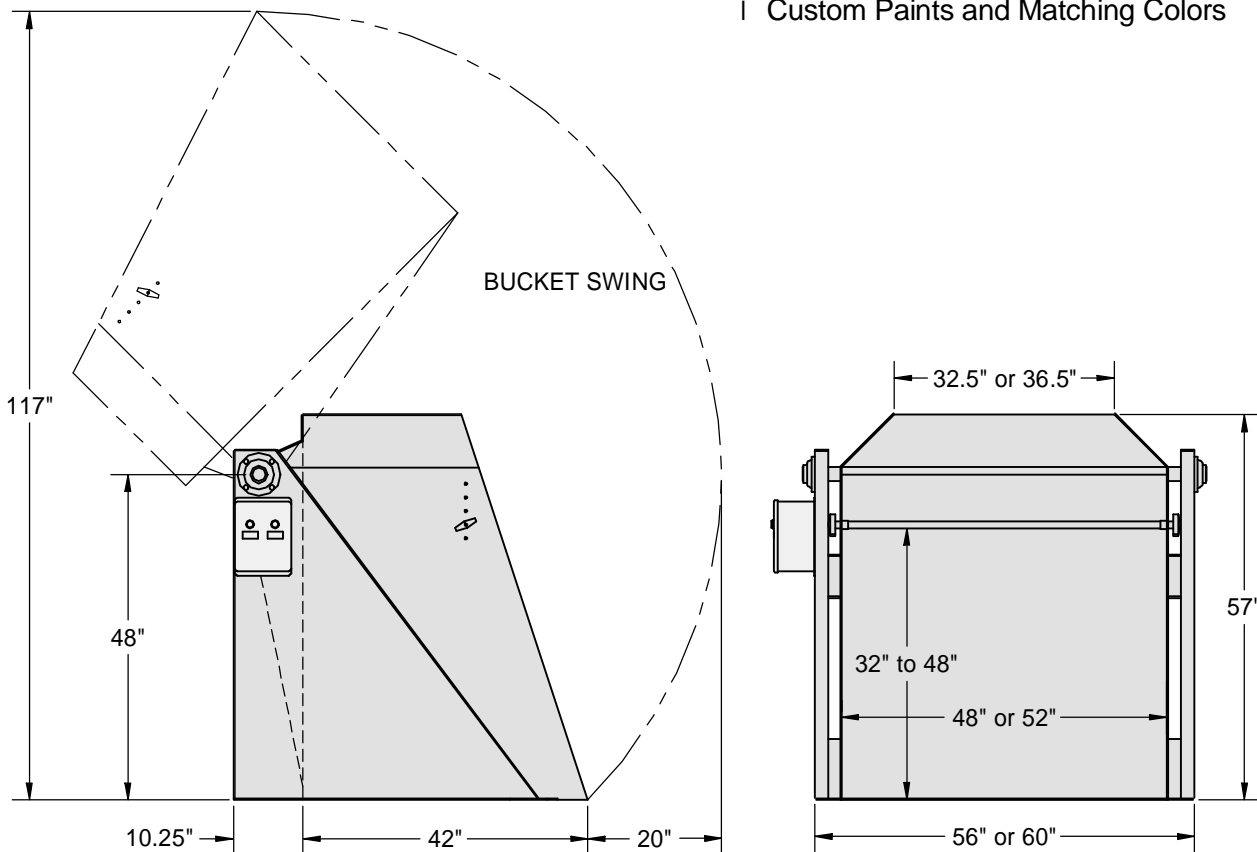

Model No.	Description
35-2500	Premier Dumper, Rear Load, 2500 lbs, Cap., 3 Phase, 48" Wide Bucket
35-2550	Premier Dumper, Rear Load, 2500 lbs. Cap., Single Phase, 48" Wide Bucket
35-5200	Premier Dumper, Rear Load, 2500 lbs. Cap., 3 Phase, 52" Wide Bucket
35-5250	Premier Dumper, Rear Load, 2500 lbs. Cap., Single Phase, 52" Wide Bucket

N60 W14459 Kaul Avenue
 Menomonee Falls, WI 53051
 Phone: 262-703-0890
 Fax: 262-703-0895
 Email: sales@aquapoly.com
www.aquapoly.com



Premier Diagonal Box Dumper

The Premier Diagonal Box Dumper is designed and built for continuous operation. It features 2" piloted roller bearings at the main pivot and bronze sleeve bearings at the top cylinder mounts. We use a proven 1.5 h.p. hydraulic package with easy to service components and a separate oil reservoir.

Designed for increased safety, this unit has solid side panels on the frame and a wider clearance between the frame and bucket to eliminate pinch points. The unit can be stopped anywhere in the up and down cycle simply by releasing the push button control.

Our standard units all have 2500# lift capacity and a gravity return. Units are powered by a pair of 2" bore, 2" rod, ram style cylinder. Special dust control and other hooded units use cylinders with a 3" bore and are powered on both the up and down cycles.



See back page for additional specifications.

All Ensign Equipment Inc. products carry a TWO YEAR warranty covering defects in manufacture, workmanship and components. Also all STANDARD products are covered by the Ensign Advantage, a 30 day trial period guaranteeing customer satisfaction!

Model No.	Description
36-2500	Premier Diagonal Dumper, 2500 lbs, Cap., 3 Phase
36-2550	Premier Diagonal Dumper, 2500 lbs, Cap., Single Phase

N60 W14459 Kaul Avenue
Menomonee Falls, WI 53051
Phone: 262-703-0890
Fax: 262-703-0895
Email: sales@aquapoly.com
www.aquapoly.com



**QUA POLY
EQUIPMENT CO.**

Premier Diagonal Box Dumper

Standard Features:

- | Bucket Rotation 135 deg.
- | Motor 1.5 h.p.
- | NEMA 12 Electrical Enclosure
- | Hydraulic Cylinders w/ 24" stroke, 2" bore, 2" rod
- | Adjustable Retaining Bar 32" to 48"
- | Up Cycle Completion, Limit Switch
- | Down Cycle Flow Control Valve
- | Cycle Time- 30 sec. Up, 15 sec. Down
- | Replaceable Pivot Bearings
- | Ensign Blue Epoxy

Optional Features:

- | Velocity fuse, (catches bucket in case of hydraulic rupture)
- | Custom Size and Shape Buckets
- | Dust Hood with Discharge Hatch
- | Dust Containment hood on Bucket
- | Dumper Stands 12" to 72"
- | Double Acting Hydraulics
- | Explosion Proof Electrical
- | Stainless Steel Chute Liner
- | Stainless Steel Construction
- | Custom Paints and Matching Colors

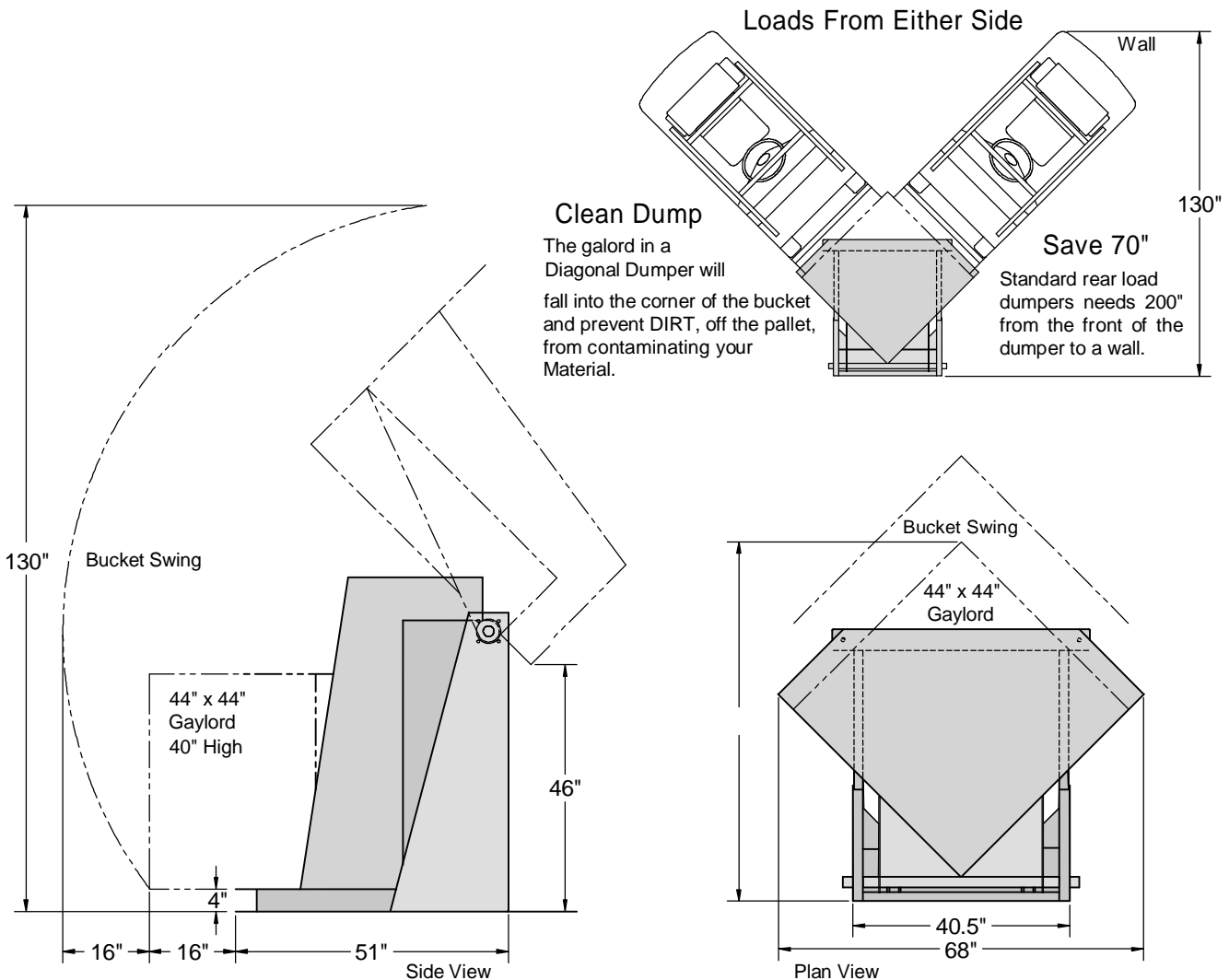

N60 W14459 Kaul Avenue
Menomonee Falls, WI 53051
Phone: 262-703-0890
Fax: 262-703-0895
Email: sales@aquapoly.com
www.aquapoly.com



Hydraulic Lift & Dump

The Hydraulic Lift & Dump is designed and built for continuous operation. It features 2" roller bearings at the main pivot and bronze sleeve bearings at the top cylinder mounts. We use a proven 2 hp hydraulic power unit with integral pump and oil reservoir.

Designed for increased safety, this unit has expanded metal side panels on the frame and a wider clearance between the frame and bucket to eliminate pinch points. The unit can be stopped anywhere in the up and down cycle simply by releasing the push button control.

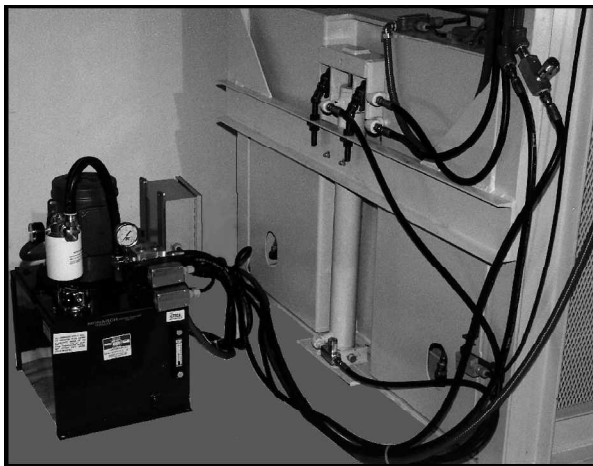

Hydraulic power unit with 10 foot hose.



Our standard units all have 2500# lift capacity with double acting hydraulics. Units are powered by a 3" mast cylinder and a pair of 2" bore, 1.5" rod dump cylinders. Special dust control hoods and other custom bucket designs are available options on these heavy duty units.

Hydraulic Lift & Pump

Standard Features:

- | Bucket Rotation 135 deg.
- | Motor 2 hp
- | NEMA 12 Electrical Enclosure
- | Double Acting Hydraulics
- | Lift Cylinder, 3" bore, 1.5" rod
- | Dump Cylinders w/ 24" stroke, 2" bore, 1.5" rod
- | Adjustable Retaining Bar 32" to 48"
- | Up Cycle Completion, Limit Switch
- | Down Cycle Flow Control Valves
- | Cycle Time- 45 sec. Up, 45 sec. Down
- | Velocity fuse, in Lift Cylinder
- | Replaceable Pivot Bearings
- | Blue Epoxy

Optional Features:

- | Gaylord Entry Guides
- | Custom Size and Shape Buckets
- | Dust Hood with Discharge Hatch
- | Dust Containment Doors on Bucket
- | Floor Grate in Bucket
- | Explosion Proof Electrical
- | Stainless Steel Chute Liner
- | Stainless Steel Construction
- | Custom Paints and Matching Colors

All Ensign Equipment Inc. products carry a TWO YEAR warranty covering defects in manufacture, workmanship and components.

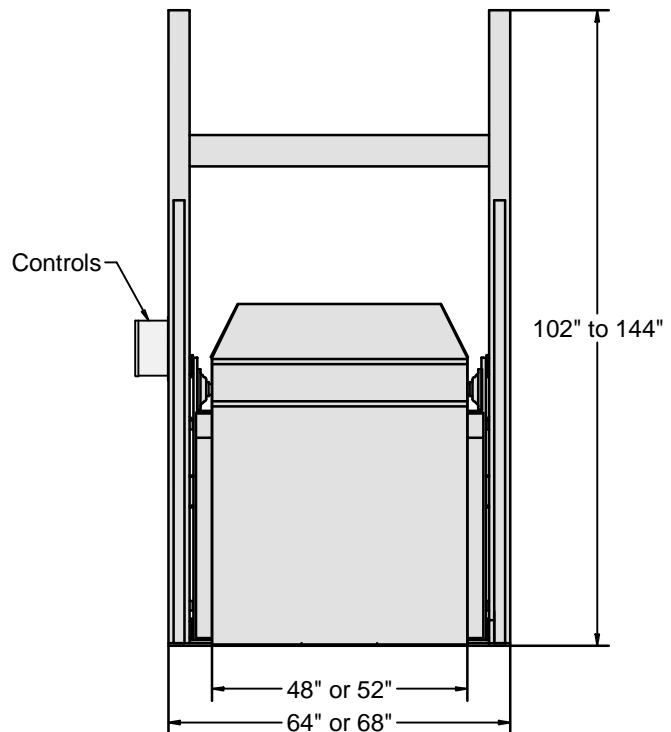
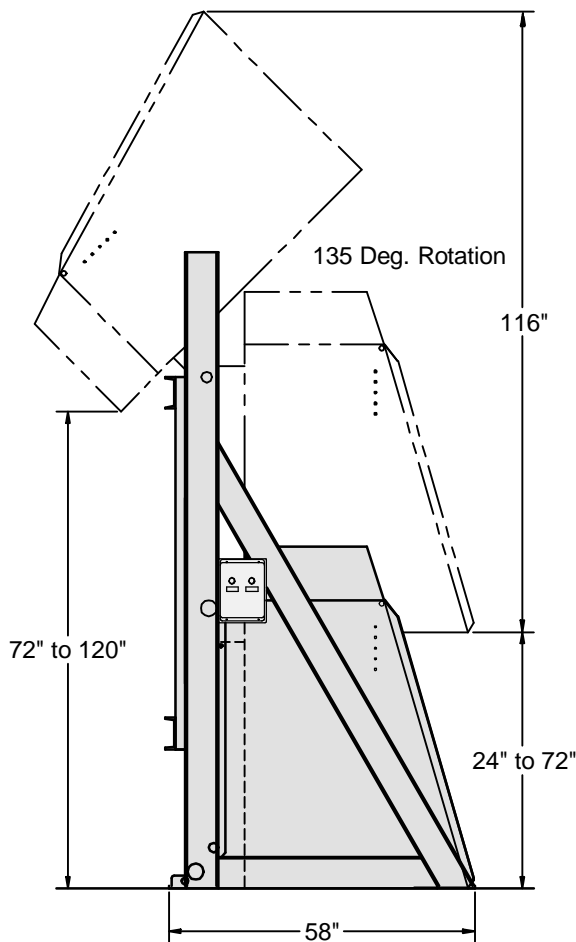

N60 W14459 Kaul Avenue
Menomonee Falls, WI 53051
Phone: 262-703-0890
Fax: 262-703-0895
Email: sales@aquapoly.com
www.aquapoly.com



Portable Vertical Auger Batch Mixers

The Portable Batch Mixer is designed to economically mix free flowing bulk solid materials. Its heavy duty 6" auger lifts the material up from the bottom of the hopper and disperses it around the top. Portable Batch Mixers comes in sizes ranging from 10 to 60 cu.ft. with a variety of fill and discharge options.

We have introduced many new features to this style of mixer. We have installed an inverted bottom sleeve bearing that prevents the auger from contacting the auger tube. Our internal safety cover switches have made the unit safer to operate and our bottom discharge roller slide gate has made jammed slide gates a thing of the past.

The 44" square leg pattern will fit Portable Storage Bins and Power Hoppers as well as a variety of mixer discharge stands. Our Gravity Discharge Stand will allow you to place the mixer high enough to gravity discharge into gaylords. The auger discharge stands will deliver your mixed material to a machine or a storage vessel and the Vacuum Discharge Stand will enable you to deliver your mixed material directly into your vacuum system.



We can adapt these mixers to your particular needs and we can custom build them to fit any situation.

See back page for additional specifications.

All Ensign Equipment Inc. products carry a TWO YEAR warranty covering defects in manufacture, workmanship and components. Also all STANDARD products are covered by the Ensign Advantage, a 30 day trial period guaranteeing customer satisfaction!

Portable Batch Mixers

Standard Features:

- | Double Hinged Covers
- | 6" OD Agitator Auger
- | Roller Slide Gate
- | Two Way Fork Channels
- | 14 ga Hopper, w 10 ga Legs
- | Push Button Start Stop
- | 30 min. Cycle Timer
- | NEMA 12 Electrical Enclosure
- | Safety Shut Off Switches in Covers
- | Motor, TEFC 3/4 to 2 h.p.
- | Direct Gear Drive
- | Blue Epoxy

Optional Features:

- | Easy Clean Hinged Auger Tube
- | Vacuum Loader Mounting Hole in Cover
- | Dump Chute Adaptor
- | Auger Inlet Adaptor
- | 304 SS Hopper and Auger Assembly
- | Gaylord Discharge Stand
- | Auger Discharge Stand
- | Vacuum Discharge Stand
- | Custom Paints and Matching Colors

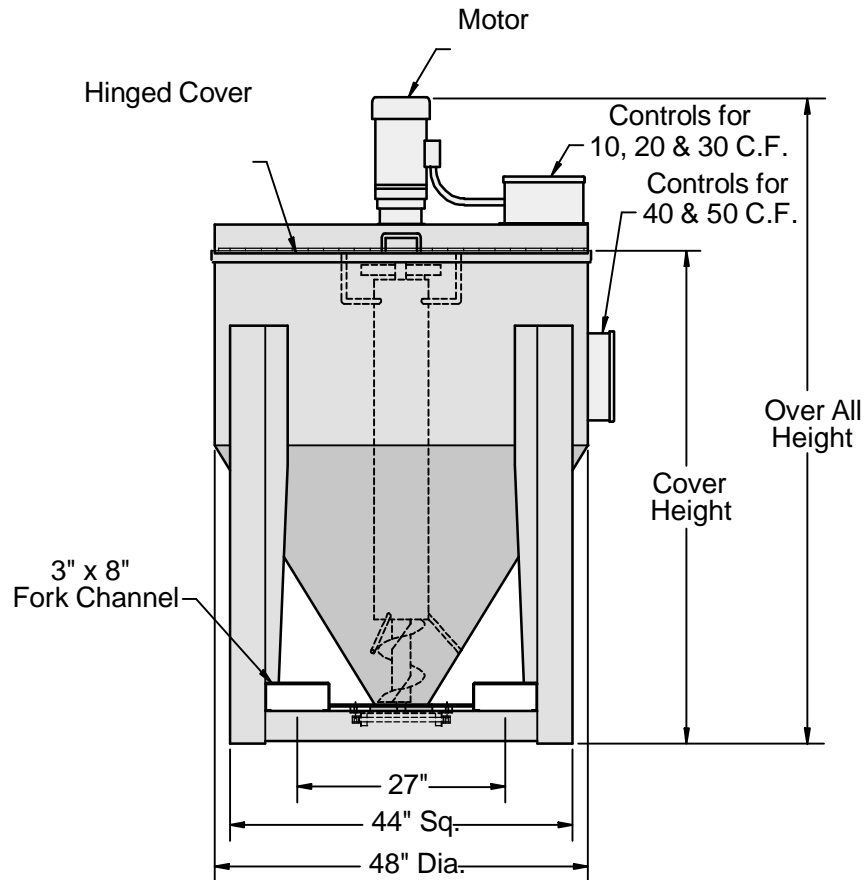

Model No. 1 ph. Elec.	Model No. 3 ph. Elec.	Description	Cover Height	Overall Height
60-1000	60-1200	Portable Batch Mixer, 10 cu. ft.	40.5"	60"
60-2000	60-2200	Portable Batch Mixer, 20 cu. ft.	46.5"	66"
60-3000	60-3200	Portable Batch Mixer, 30 cu. ft.	56.5"	76"
60-4000	60-4200	Portable Batch Mixer, 40 cu. ft.	66.5"	86"
60-5000	60-5200	Portable Batch Mixer, 50 cu. ft.	76.5"	96"

N60 W14459 Kaul Avenue
 Menomonee Falls, WI 53051
 Phone: 262-703-0890
 Fax: 262-703-0895
 Email: sales@aquapoly.com
www.aquapoly.com



Portable Vertical Ribbon Mixer



The Portable Powder Mixer is a vertical ribbon type mixer, designed for materials that cannot be satisfactorily mixed in our standard line on vertical auger mixers. This versatile unit is mobile, adaptable to other in-plant equipment, and easy to clean. By drawing material up the sidewalls of the vessel, we have been able to achieve exceptional results blending most plastic powders. This unit also does well with dissimilar materials such as mixing a powder with a granule or regrind. We would be pleased to arrange an evaluation or test of your material!

The 44" square leg pattern will fit Portable Storage Bins and Power Hoppers as well as a variety of mixer discharge stands. Our Gravity Discharge Stand will allow you to place the mixer high enough to gravity discharge into Gaylords. The auger discharge stands will deliver your mixed material to a machine or a storage vessel and the Vacuum Discharge Stand will enable you to deliver your mixed material directly into your vacuum system.

See back page for additional specification.

Model No.	Mixer Cap.	Mixing Time
65-1000	16 cu. ft.	7 min.
65-2000	26 cu. ft.	10 min.

All Ensign Equipment Inc. products carry a TWO YEAR warranty covering defects in manufacture, workmanship and components. Also all STANDARD products are covered by the Ensign Advantage, a 30 day trial period guaranteeing customer satisfaction!

N60 W14459 Kaul Avenue
Menomonee Falls, WI 53051
Phone: 262-703-0890
Fax: 262-703-0895
Email: sales@aquapoly.com
www.aquapoly.com

**QUA POLY
EQUIPMENT CO.**

Portable Vertical Ribbon Mixer

Standard Features:

- | Motor-7.5 hp, 3 PH
- | Gear Drive- Nord
- | Conical Ribbon Agitator
- | Idler Bearing- Rulon
- | Swing Gate Discharge
- | Two Way Fork Channels
- | Bolt Down Feet
- | Two Way Hinged Covers
- | Safety Interlock Cover Switches
- | Cycle Timer- 30 Min.
- | Electrical- Nema 12
- | Blue Epoxy

Optional Features:

- | Dump Chute Intake
- | Bolt On Cover w/ Loader Pattern
- | Gravity Discharge Stand
- | Auger Discharge Stand
- | Vacuum Discharge Stand
- | Casters
- | Custom Paints and Matching Colors

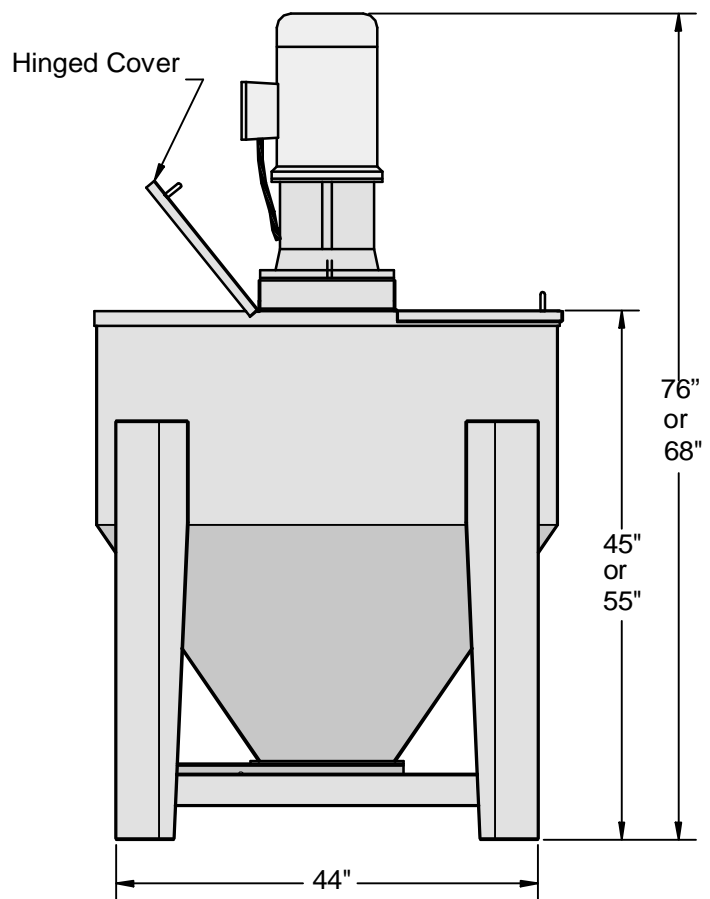
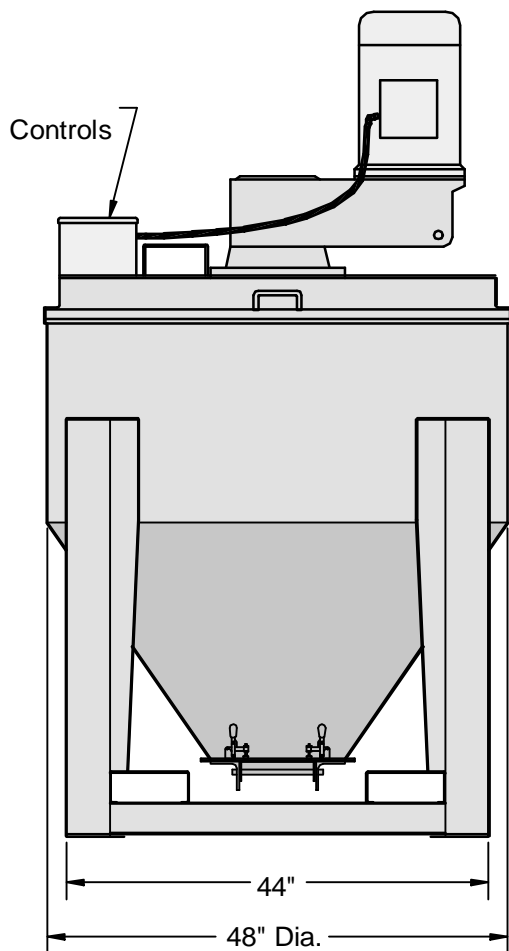

N60 W14459 Kaul Avenue
Menomonee Falls, WI 53051
Phone: 262-703-0890
Fax: 262-703-0895
Email: sales@aquapoly.com
www.aquapoly.com



Stationary Vertical Auger Mixers

The Stationary Vertical Auger Mixer is designed to economically mix free flowing bulk solid materials. Its heavy duty auger lifts the material up from the bottom of the hopper and disperses it around the top. Stationary Mixers comes in sizes ranging from 30 to 1200 cu.ft. with a variety of fill and discharge options.

We have introduced many new features to this style of mixer. We have installed an inverted bottom sleeve bearing that centers the auger while eliminating the possibility of grease contamination of your material. We use interlocking safety switches to make the unit safer to operate and our bottom discharge rack and pinion slide gate has made jammed gates a thing of the past.

Our extended legs option would allow you to place the mixer high enough to gravity discharge into gaylords. The optional auger discharge would deliver your mixed material to a machine or storage vessel or Vacuum Discharge would enable you to deliver your mixed material directly into your vacuum system.



**72" Dia. Mixer with Dumper
Infeed and Auger Discharge**

We can adapt these mixers to your particular needs and can custom build them to fit any situation.

See back page for additional specifications.

All Ensign Equipment Inc. products carry a TWO YEAR warranty covering defects in manufacture, workmanship and components.

Stationary Vertical Auger Mixers

48" Diameter Mixers

Model #	Capacity	Vert. Side
61-4800	30 cu. ft.	22"
61-4810	40 cu. ft.	32"
61-4820	50 cu. ft.	42"
Auger Size - 6" OD Industrial		
Motor Size - 3-5 H.P., 3ph.		
Auger Speed - 375 RPM		
Ratio of Belt Drive - 4.5 :1		
Slide Gate Size - 8"		
Cone Capacity - 14 cu. ft.		
Capacity Per Vert. Ft. - 12 cu. ft.		

61" Diameter Mixers

Model #	Capacity	Vert. Side
61-6100	60cu. ft.	24"
61-6110	80 cu. ft.	36"
61-6120	100 cu. ft.	48"
Auger Size - 9" OD Industrial		
Motor Size - 7.5 H.P., 3ph.		
Auger Speed - 345 RPM		
Ratio of Belt Drive - 5 :1		
Slide Gate Size - 12"		
Cone Capacity - 28 cu. ft.		
Capacity Per Vert. Ft. - 20 cu. ft.		

72" Diameter Mixers

Model #	Capacity	Vert. Side
61-7200	143 cu. ft.	48"
61-7210	171 cu. ft.	60"
61-7220	200 cu. ft.	72"
Auger Size - 12" OD Industrial		
Motor Size - 10-15 H.P., 3ph.		
Auger Speed - 287 RPM		
Ratio of Belt Drive - 6 :1		
Slide Gate Size -14"		
Cone Capacity - 47 cu. ft.		
Capacity Per Vert. Ft. - 28 cu. ft.		

90" Diameter Mixers

Model #	Capacity	Vert. Side
61-9000	250 cu. ft.	48"
61-9010	335 cu. ft.	72"
61-9020	425 cu. ft.	96"
Auger Size - 14" OD Industrial		
Motor Size - 20-25 H.P., 3ph.		
Auger Speed - 287 RPM		
Ratio of Belt Drive - 6 :1		
Slide Gate Size - 16"		
Cone Capacity - 95 cu. ft.		
Capacity Per Vert. Ft. - 44 cu. ft.		

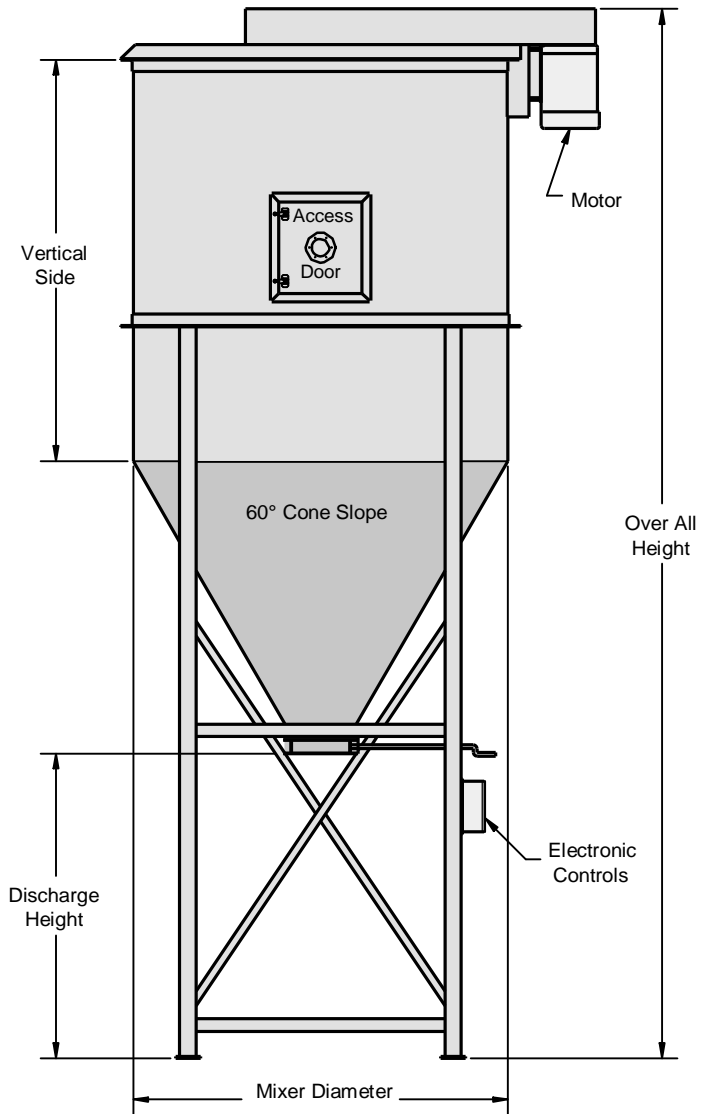

Features & Options

	48" Dia.	61" Dia.	72" Dia.	90" Dia.
Start-Stop Controls -----	Std.	Std.	Std.	Std.
Bolt Down Feet -----	Std.	Std.	Std.	Std.
Rack & Pinion Slide Gate----	Std.	Std.	Std.	Std.
Top Access Hatch -----	Std.	Std.	Option	Option
Side Access Door -----	Option	Option	Std.	Std.
Loader Mounting Pattern ----	Option	Option	Std.	Std.
Side Mount Discharge Gate -	Option	Option	Option	Option
Dumper Fill Chute -----	Option	Option	Option	Option
View Windows -----	Option	Option	Option	Option
Extended Legs -----	Option	Option	Option	Option
Vacuum Discharge -----	Option	Option	Option	Option

Power Hopper



The Power Hopper is designed to feed pellets, granules and free flowing powders into an overhead hopper or storage vessel. It is often used in conjunction with our Hydraulic Dumping unit to deliver material fast and efficiently from gaylords to point of use. Power Hoppers are built with a variety of auger sizes and types and can deliver from 10 to 500 cu.ft. of material per hour.

Ensign Equipment Power Hoppers are built to last with a heavy duty gear drive and an adjustable teflon shaft seal. See back page for additional specifications.

All Ensign Equipment Inc. products carry a TWO YEAR warranty covering defects in manufacture, workmanship and components. Also all STANDARD products are covered by the Ensign Advantage, a 30 day trial period guaranteeing customer satisfaction!

Power Hopper Specifications

Model No.	Screw Dia.	Tube Dia.	RPM	HP	Max Length	Slope	Delivery/ hr.
20-1100	2.7*	3.5"	345	1.5	50'	60deg.	50 cu.ft.
20-2100	2.7*	3.5"	345	1.5	50'	45deg.	60 cu.ft.
20-3100	3.8*	5"	345	2	30'	60deg.	100 cu.ft.
20-4100	3.8*	5"	345	2	30'	45deg.	120 cu.ft.
20-5100	4"	5"	230	2	20'	60deg.	150 cu.ft.
20-6100	4"	5"	230	2	20'	45deg.	180 cu.ft.

* Coreless Augers- Coreless Augers need no hanger bearings and can incorporate a 60" radius elbow. NOTE: delivery rates on this chart are an approximation based on average materials under average conditions. Check with us before order ordering to make sure the model you have selected will meet your requirements.

N60 W14459 Kaul Avenue
Menomonee Falls, WI 53051
Phone: 262-703-0890
Fax: 262-703-0895
Email: sales@aquapoly.com
www.aquapoly.com



Power Hopper

Standard Features:

- | Direct Gear Drive for low maintenance
- | 20 cu.ft. Hopper Capacity
- | Hopper Dimension 44" x 44" x 46" high
- | Quick Disconnect Auger for easy cleaning
- | Compressible Teflon Seal
- | Two Way Fork Channels
- | Stacking Pads for Portable Storage Bins
- | Foot Pads to secure the unit to the floor
- | 12 ga. Hopper with 1/4" Bent Angle Legs
- | 45 deg. or 60 deg. Auger Slope
- | Electrical Controls with On-Off Selector
- | NEMA 12 Electrical Enclosure
- | Ensign Blue Epoxy

Optional Features:

- | 30 cu. ft. Hopper Capacity, 56" high
- | Bag Breaker Grate
- | Continuous Hinged Cover
- | Vibrator
- | Casters (2 swivel, 2 rigid locking)
- | Variable Speed Drive
- | Explosion Proof Electrical
- | Level Control Switch
- | Stainless Steel Construction
- | Custom Paints and Matching Colors

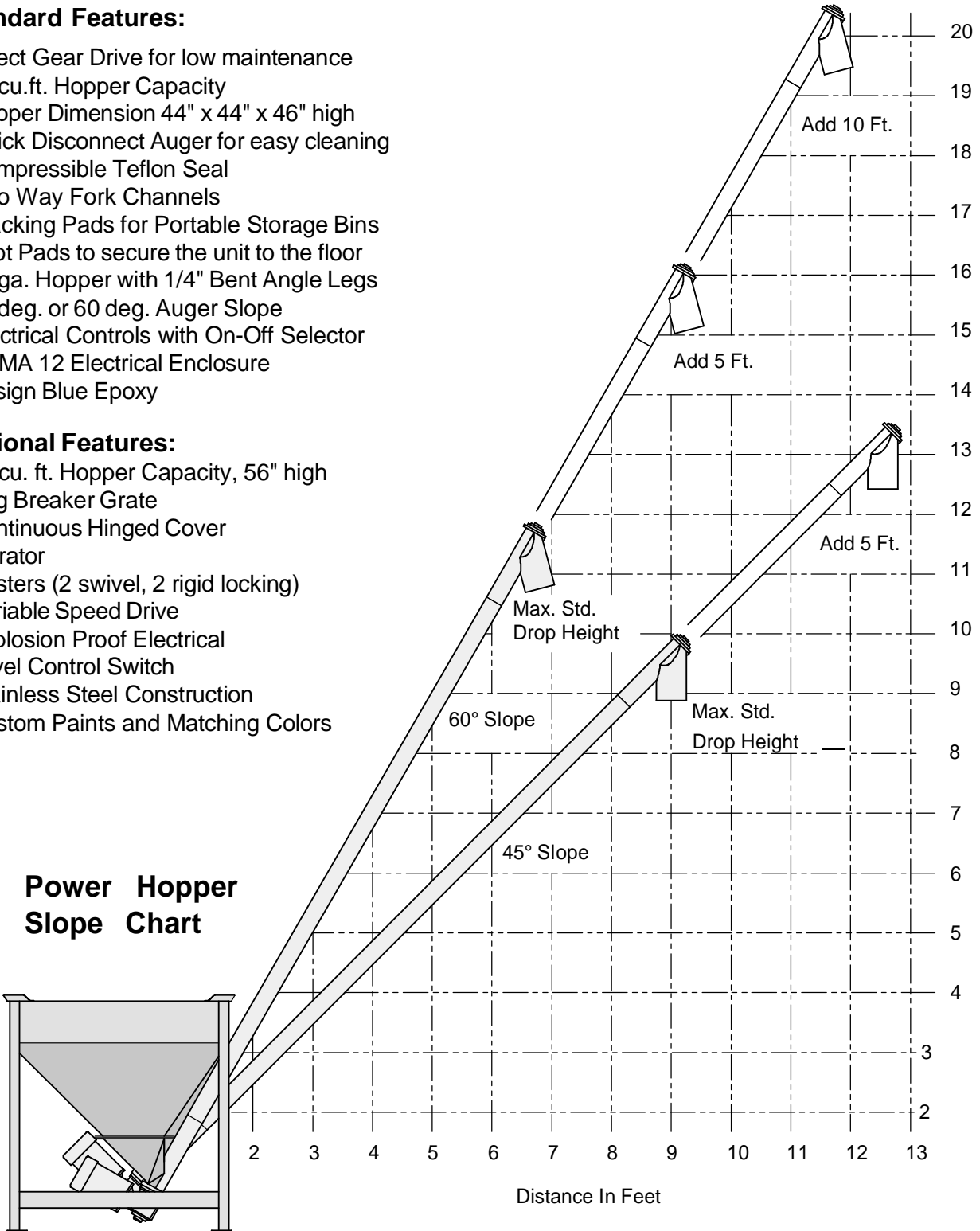

N60 W14459 Kaul Avenue
 Menomonee Falls, WI 53051
 Phone: 262-703-0890
 Fax: 262-703-0895
 Email: sales@aquapoly.com
www.aquapoly.com



Live Bottom Power Hopper

The Ensign Equipment Live Bottom Power Hopper is designed to feed sluggish powders, flakes, and other hard-to-move materials into an overhead hopper or storage vessel. It is often used in conjunction with our Hydraulic Dumper to deliver material fast and efficiently from Gaylord to point of use. Live Bottom Power Hoppers are built with two sizes of coreless auger that can deliver between 50 and 120 cu. ft. per hour. If higher delivery rates are required you may need a High Capacity Live Bottom Bin with Tubular Screw Conveyor.



All Ensign Equipment Inc. products carry a TWO YEAR warranty covering defects in manufacture, workmanship and components. Also all STANDARD products are covered by the Ensign Advantage, a 30 day trial period guaranteeing customer satisfaction!

Live Bottom Specifications

Model No.	Screw Dia.	Tube Dia.	RPM	HP	Max Length	Slope	Delivery/hr.
20-1200	2.7	3.5	345	1.5	30'	to 60 deg.	50 cu. ft.
20-3200	3.8	5	345	2	20'	to 60 deg.	100 cu. ft.

N60 W14459 Kaul Avenue
 Menomonee Falls, WI 53051
 Phone: 262-703-0890
 Fax: 262-703-0895
 Email: sales@aquapoly.com
www.aquapoly.com



Live Bottom Power Hopper

Standard Features:

- | Direct Gear Drive for low maintenance
- | 12 cu. ft. Hopper, 44" x 44" x 46" high
- | Quick Disconnect Auger for easy cleaning
- | Compressible Teflon Dust Seal
- | Two Way Fork Channels for easy portability
- | Foot Pads to secure unit to floor
- | Stacking Pads to fit Portable Storage Bins or a Portable Batch Mixer
- | 12 Gauge Hopper with 1/4" bent angle legs
- | 15, 30, 45, and 60 deg. auger slope
- | Ensign Blue Epoxy

Optional Features:

- | 22 cu. ft. Capacity Hopper, 56" high
- | Bag Break Grate
- | Continuous Hinged Covers
- | Vibrator
- | Agitator
- | Casters (2 swivel, 2 rigid locking)
- | Variable Speed Drive
- | Level Control Switch
- | Motor Controls with Start-Stop
- | Custom Paints and Matching Colors

Live Bottom Slope Chart

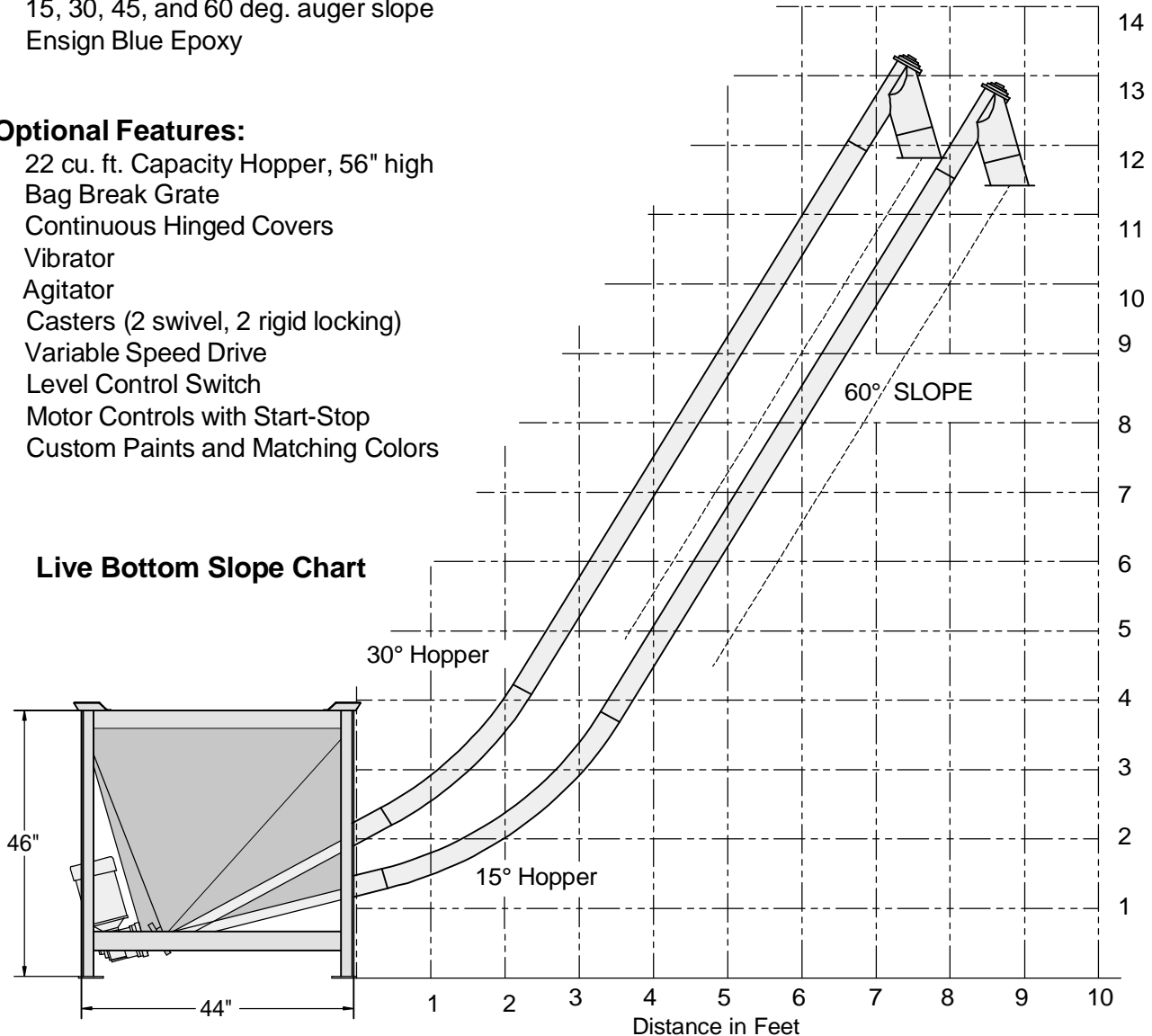

N60 W14459 Kaul Avenue
Menomonee Falls, WI 53051
Phone: 262-703-0890
Fax: 262-703-0895
Email: sales@aquapoly.com
www.aquapoly.com



Easy-Clean Hopper Loader

The Hopper Loader is designed to feed pellets, granules and free flowing powders into an overhead hopper or storage vessel. It can be used with bags or portable storage bins. It is often used to avoid climbing ladders with bags or buckets of material. Hopper Loader is equipped with 2.7" flex auger that will deliver up to 60 cu. ft. of material to an over head hopper.

The unique part about this hopper loader is its easy clean feature. The machine can be broken down for wipe out cleaning in less than two minutes.

Ensign Equipment Hopper Loaders are built to last with a heavy duty body, bearings, and an adjustable teflon shaft seal to protect the belt drive. See back page for additional specifications.



All Ensign Equipment Inc. products carry a TWO YEAR warranty covering defects in manufacture, workmanship and components. Also all STANDARD products are covered by the Ensign Advantage, a 30 day trial period guaranteeing customer satisfaction!

Hopper Loader Specifications

Model No.	Screw Dia.	Tube Dia.	RPM	HP	Max Length	Slope	Delivery/ hr.
20-1600	2.7	3.5"	438	.75	12'	75deg.	60 cu.ft.

N60 W14459 Kaul Avenue
Menomonee Falls, WI 53051
Phone: 262-703-0890
Fax: 262-703-0895
Email: sales@aquapoly.com
www.aquapoly.com



Easy-Clean Hopper Loader

Standard Features:

- | Flip Over Hopper (for Easy Cleaning)
- | 4:1 Belt Drive
- | 5 cu.ft. Hopper Capacity
- | Hopper Dimension 24" x 26" x 32" high
- | Quick Disconnect Auger (for easy cleaning)
- | Compressible Teflon Seal
- | Casters, 2 rigid (for Easy Mobility)
- | 14 ga. Hopper with 10ga. Base
- | 75 deg. Auger Slope
- | Electrical Controls with On-Off Selector
- | NEMA 12 Electrical Enclosure
- | Ensign Blue Epoxy

Optional Features:

- | Bag Breaker Grate
- | Continuous Hinged Cover
- | Vibrator
- | Variable Speed Drive
- | Level Control Switch
- | Stainless Steel Construction
- | Custom Paints and Matching Colors

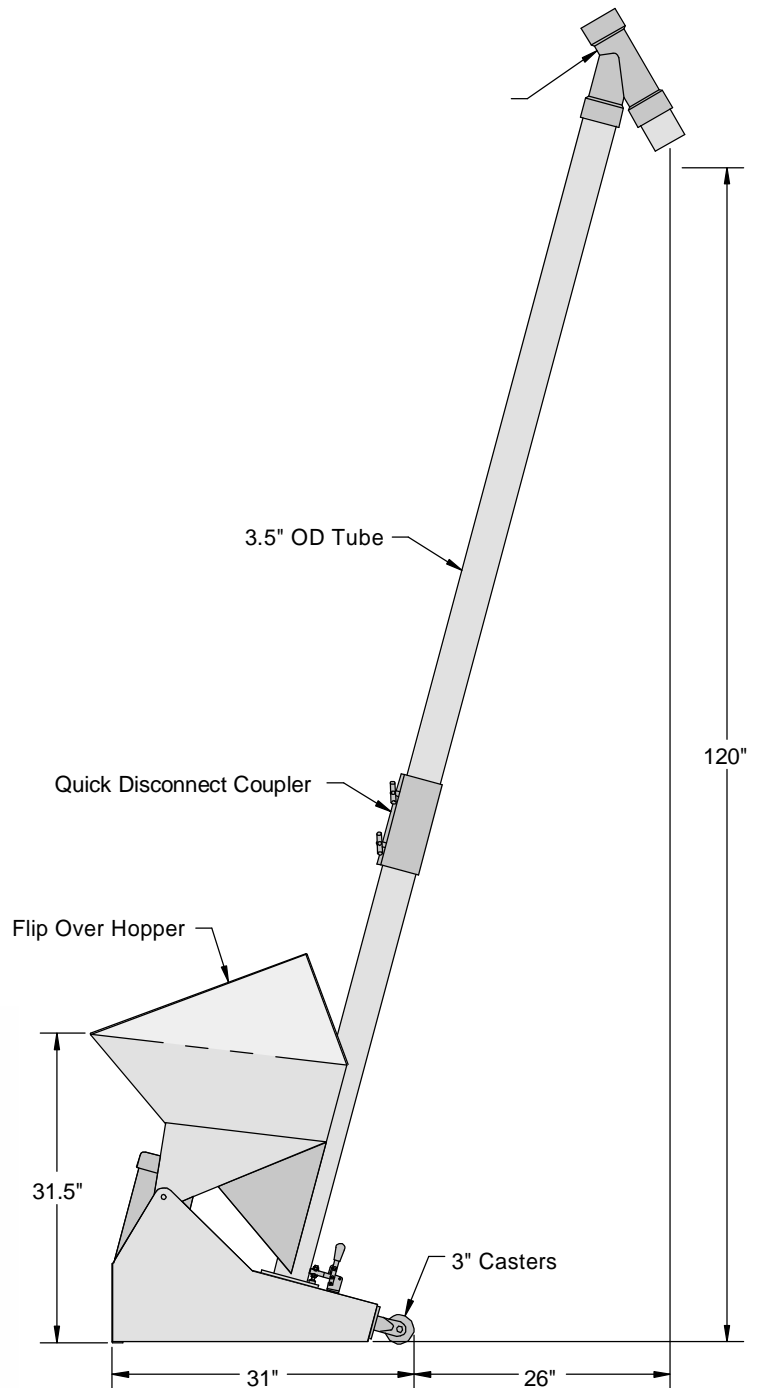

N60 W14459 Kaul Avenue
Menomonee Falls, WI 53051
Phone: 262-703-0890
Fax: 262-703-0895
Email: sales@aquapoly.com
www.aquapoly.com



Granulator Unloader

Model 20-1500

The ENSIGN EQUIPMENT INC. Granulator Unloader is designed to replace the catch box on many brands of granulator. These units will deliver up to 2000 pounds per hour of ground plastic to a Gaylord container or portable storage hopper. These durable, economical units relieve your operator from having to check the fullness of drawers and emptying them, saving both down time from over packed drawer and your operators back.

Standard Features:

- | Direct Gear Drive for low maintenance
- | 2.7" Flex Auger in 3.5" OD Tube
- | 45 deg. Hardened Elbow
- | 60" Discharge Height
- | Custom Drawer to Fit Granulator
- | Controls with Start-Stop Buttons
- | NEMA 12 Electrical
- | Casters, 2 rigid
- | Ensign Blue Epoxy

Optional Features:

- | Vibrator
- | Variable Speed Drive
- | Explosion Proof Electrical
- | Level Control Switch
- | Stainless Steel Construction
- | Custom Paints and Matching Colors



All Ensign Equipment Inc. products carry a TWO YEAR warranty covering defects in manufacture, workmanship and components. Also all STANDARD products are covered by the Ensign Advantage, a 30 day trial period guaranteeing customer satisfaction!

N60 W14459 Kaul Avenue
Menomonee Falls, WI 53051
Phone: 262-703-0890
Fax: 262-703-0895
Email: sales@aquapoly.com
www.aquapoly.com

**AQUA POLY
EQUIPMENT CO.**

N60 W14459 Kaul Avenue
Menomonee Falls, WI 53051
Phone: 262-703-0890
Fax: 262-703-0895
Email: sales@aquapoly.com
www.aquapoly.com



Tubular Screw Conveyors

Screw Conveyors are most effective when moving large amounts of material over short distances. We have developed a standard line of Tubular Screw Conveyors that range in capacity from 50 cu. ft. to 700 cu. ft. per hour. These Screw Conveyors are particularly good for moving dusty material because they can be completely sealed. Our direct drive system is more compact and easier to maintain than other commonly used drives.

Ensign Equipment offers a complete line of screw conveying equipment including: discharge adapters, support stands, suspension brackets, level control switches, and control packages. We can also custom design screw conveyors to fit your particular material handling needs!



All Ensign Equipment Inc. products carry a TWO YEAR warranty covering defects in manufacture, workmanship and components. Also all STANDARD products are covered by the Ensign Advantage, a 30 day trial period guaranteeing customer satisfaction!

N60 W14459 Kaul Avenue
Menomonee Falls, WI 53051
Phone: 262-703-0890
Fax: 262-703-0895
Email: sales@aquapoly.com
www.aquapoly.com



Tubular Screw Conveyors

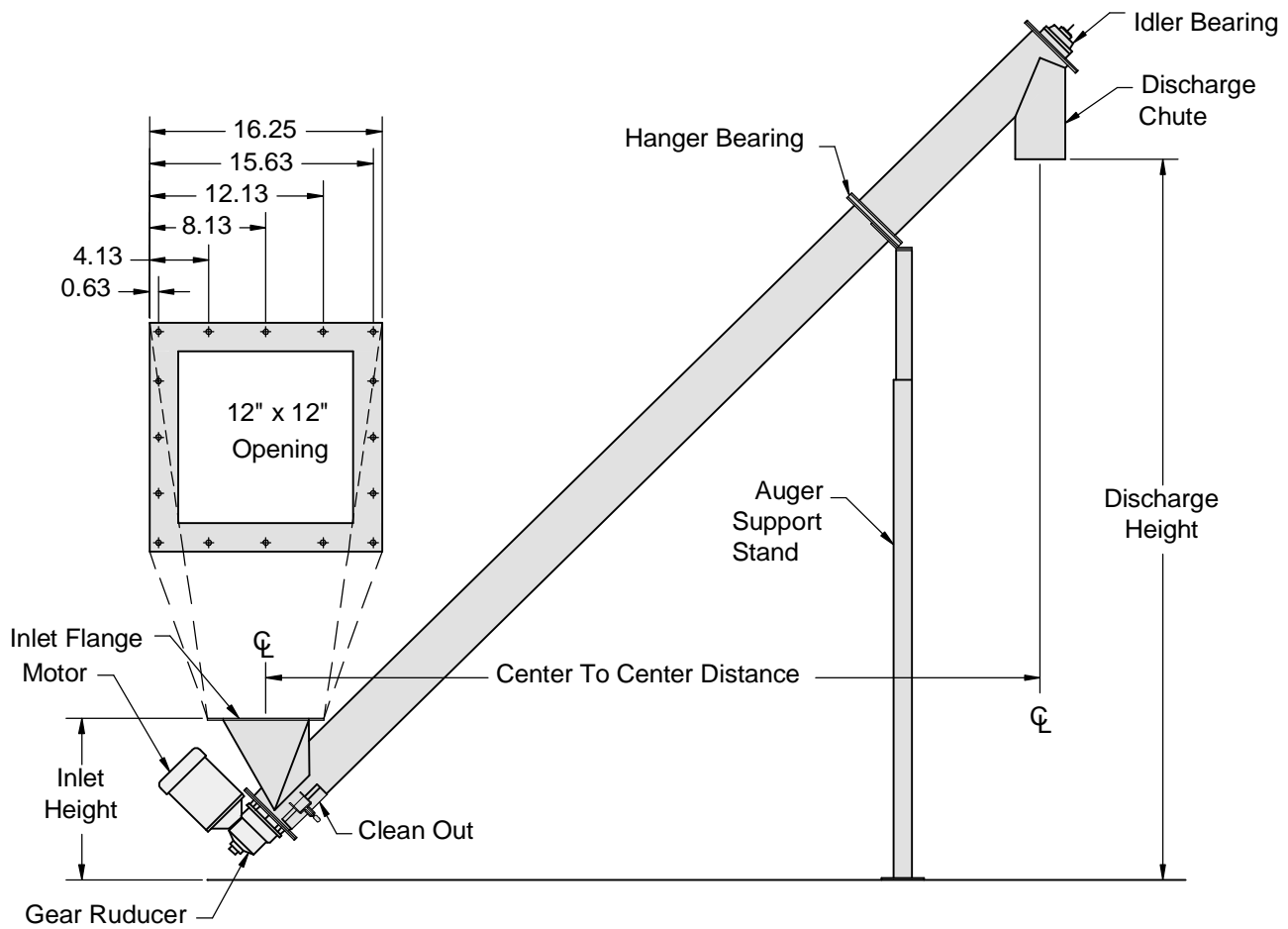

Screw Conveyor Specifications

Model No.	Screw Dia.	Tube Dia.	RPM	HP	Max Length	Slope	Delivery/Hr.
20-1000	2.7*	3.5"	345	1.5	50'	60 deg.	50 c.f.
20-2000	2.7*	3.5"	345	1.5	50'	45 deg.	60 c.f.
20-3000	3.8*	5"	345	2	30'	60 deg.	100 c.f.
20-4000	3.8*	5"	345	2	30'	45 deg.	120 c.f.
20-5000	4	5"	232	2	30'	60 deg.	150 c.f.
20-6000	4	5"	232	2	30'	45 deg.	180 c.f.
21-1000	6	7"	232	3	30'	60 deg.	280 c.f.
21-2000	6	7"	232	3	30'	45 deg.	320 c.f.
21-3000	9	10"	173	5	30'	60 deg.	600 c.f.
21-4000	9	10"	173	5	30'	45 deg.	700 c.f.

*Coreless Augers - Coreless Augers need no hanger bearing and can incorporate a 60" radius elbow.
 NOTE: Delivery rates on this chart are approximations based on average materials under average conditions. Check with us before ordering to make sure the model you have selected will meet your requirements.

N60 W14459 Kaul Avenue
 Menomonee Falls, WI 53051
 Phone: 262-703-0890
 Fax: 262-703-0895
 Email: sales@aquapoly.com
www.aquapoly.com



Super Sack Unloading Stations

Take advantage of super sack material pricing with an economical in plant super sack unloading system. We custom design super sack stations that are convenient to use and fit both your budget and your material handling requirements.

Our most popular model is this manual fork lift carriage type (shown at right). Adjustable for bags ranging in size from 62" to 90" tall, shown here with an untie chamber, iris valve shut off, and a receiving hopper designed to match up to any of our standard vacuum boxes or screw conveyor systems. Contact us to see just how affordable a super sack station can be!



Optional Features:

- | 14" Iris Valve Shut Off
- | Inflatable Collar Seal
- | Dust Containment
- | Four Corner Bag Massage
- | Untie Chamber w/ 3" vent
- | 30 cu. ft. Surge Hopper
- | Level Controls or Mounts
- | View Windows
- | Bag Liner Retainer
- | Custom Paints and Matching Colors

Standard Features:

- | 4" x 4" x 1/4" Angle Legs
- | Adjustable Carriage Support
- | Bolt Down Foot Pads
- | Super Sack Rest Pan
- | Air Box Discharge Flange
- | Ensign Blue Epoxy Paint

N60 W14459 Kaul Avenue
Menomonee Falls, WI 53051
Phone: 262-703-0890
Fax: 262-703-0895
Email: sales@aquapoly.com
www.aquapoly.com



Super Sack Unloading Stations



Take advantage of super sack material pricing with an economical in plant super sack unloading system. We custom design super sack stations that are convenient to use and fit both your budget and your material handling requirements.

Our electric hoist model enables you to use a super sack station in tighter areas, eliminating the need for a forklift. The electric hoist model (shown at left) incorporates many Ensign special features such as a dust tight untie chamber, takeaway auger and our four corner bag massaging system for difficult materials. Contact us to see just how easy custom designing a super sack system can be!

Standard Features:

- | Electric Hoist 2000 # Capacity
- | Pendant Controls
- | Manual Push-Pull Trolley
- | 4" x 4" x 1/4" Angle Legs
- | Bolt Down Foot Pads
- | Super Sack Rest Pan
- | Untie Chamber w/ 3" vent
- | Ensign Blue Epoxy Paint

Optional Features:

- | 14" Iris Valve Shut Off
- | Inflatable Collar Seal
- | Four Corner Bag Massage
- | Dust Containment
- | Power Trolley
- | 30 cu. ft. Surge Hopper
- | Air Box Discharge Flange
- | Level Controls or Mounts
- | View Windows
- | Bag Liner Retainer
- | Custom Paints and Matching Colors

N60 W14459 Kaul Avenue
Menomonee Falls, WI 53051
Phone: 262-703-0890
Fax: 262-703-0895
Email: sales@aquapoly.com
www.aquapoly.com



Bag Break Stations



The Ensign Bag Break Stations are designed to feed bagged materials in to your bulk material handling system. Bag Break units are made in modular sections so you can pick the right components for your application. We have Dust Hoods that will support a self contained dust collecting unit or ones that can be connected to your in house dust system. Our hoppers sections can be adapted to screw conveyors or a variety of pneumatic systems. We also have bag compactors, grates and bag cutters to make the job go more easily.

Ensign Equipment Bag Break Stations are built to last with a heavy duty steel construction and quality components. Custom designed units available upon request. See back page for additional specifications.

All Ensign Equipment Inc. products carry a TWO YEAR warranty covering defects in manufacture, workmanship and components.



Bag Break Stations

Hopper Features:

- | 10 cu.ft. Hopper Capacity
- | Hopper Dimension 40" x 44" x 36" high
- | Bag Rest 5" x 40"
- | Bag Breaker Grate
- | Air Box Discharge Flange
- | Ensign Blue Epoxy Paint

Dust Hood Features:

- | Hinged Cover
- | Hood Dimension 40" x 44" x 24" high
- | Dust Collector Mounting Flange, or Vent Stub for Existing Collector
- | Gas Shock Cover Support
- | Ensign Blue Epoxy

Optional Features:

- | Bag Compactor
- | Dust Collector
- | Vibrator
- | Casters (2 swivel, 2 rigid locking)
- | Air Box with 1-1/2" to 4" Probes
- | Screw Conveyor Discharge
- | Level Control Switch
- | Stainless Steel Construction
- | Custom Paints and Matching Colors



Bag Break Station Dimensions

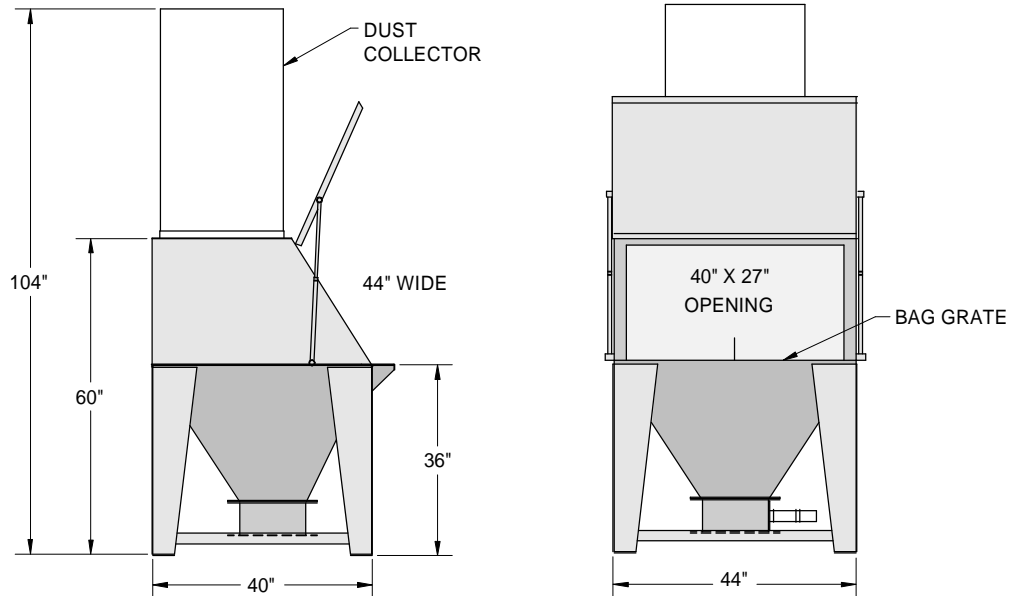

N60 W14459 Kaul Avenue
Menomonee Falls, WI 53051
Phone: 262-703-0890
Fax: 262-703-0895
Email: sales@aquapoly.com
www.aquapoly.com

